

INTERNATIONAL JOURNAL OF HIGH-ENERGY PHYSICS

# CERN COURIER

VOLUME 48 NUMBER 3 APRIL 2008



## ATLAS: the small wheels roll on

### **DARK MATTER**

New limits on the role of WIMPs p8

### **LHC FOCUS**

Keeping the beams under control p20

### **DETECTORS**

A bright future for RICH counters p27



## WIENER Multi Channel Power Supply Systems

features now the **Mpod** product range expended by mixed Versions:

### STANDARD VERSION

- Bin with module cage for 10 LV or HV modules, module size 6U x 8PU, 220mm deep
- Low Voltage floating modules with 8 channels up to 50W with 8V, 16V, 30V, 60V ranges
- High Voltage modules with 8, 16, 32 channels of 6kV, 4kV, 2,5kV or less, floating or common ground

### MIXED VERSION

- Variable divided into 2 (or more) self-contained entities:
- HV- LV cage, two to seven slots wide
- Module cage, five to fifteen slots wide for all kind of VME, cPCI, PXI backplanes
- Internal power supply with outputs for HV/LV and max. 7 independent voltages for module cage, 3kW total

### GENERAL

- Controller with Ethernet, CANbus, USB interface, interlock input
- OPC server for TCP/IP
- Graphic display for monitoring optionally
- 8U bin for bottom cooling air intake, 9U for front/lateral air intake, dust filter
- Mountable with front- or rear side outputs



Mpod from Myriapoda, Grecian = millipede

Source for trouble free Power Supply Design since 1959:

[www.wiener-d.com](http://www.wiener-d.com)

Plein & Baus GmbH, Muellersbaum 20, 51399 Burscheid, Germany  
Phone: (+49 2174) 6780, Fax: (+49 2174) 678 55



**wieNER**  
Plein & Baus Elektronik

Werk für  
Industrie-  
elektronik  
Nuklear-  
elektronik  
Regelungs-  
technik

## Covering current developments in high-energy physics and related fields worldwide

CERN *Courier* is distributed to member-state governments, institutes and laboratories affiliated with CERN, and to their personnel. It is published monthly, except for January and August. The views expressed are not necessarily those of the CERN management.

**Editor** Christine Sutton  
**Editorial assistant** Carolyn Lee  
 CERN, 1211 Geneva 23, Switzerland  
**E-mail** cern.courier@cern.ch  
**Fax** +41 (0) 22 785 0247  
**Web** cerncourier.com

**Advisory board** James Gillies, Rolf Landua and Maximilian Metzger

### Laboratory correspondents:

**Argonne National Laboratory (US)** Cosmas Zachos  
**Brookhaven National Laboratory (US)** P Yamin  
**Cornell University (US)** D G Cassel  
**DESY Laboratory (Germany)** Ilka Flegel, Ute Wilhelmssen  
**EMFCSC (Italy)** Anna Cavallini  
**Enrico Fermi Centre (Italy)** Guido Piragino  
**Fermi National Accelerator Laboratory (US)** Judy Jackson  
**Forschungszentrum Jülich (Germany)** Markus Buescher  
**GSI Darmstadt (Germany)** I Peter  
**IHEP, Beijing (China)** Tongzhou Xu  
**IHEP, Serpukhov (Russia)** Yu Ryabov  
**INFN (Italy)** Barbara Gallavotti  
**Jefferson Laboratory (US)** Steven Corneliussen  
**JINR Dubna (Russia)** B Starchenko  
**KEK National Laboratory (Japan)** Youhei Morita  
**Lawrence Berkeley Laboratory (US)** Spencer Klein  
**Los Alamos National Laboratory (US)** C Hoffmann  
**NIKHEF Laboratory (Netherlands)** Paul de Jong  
**Novosibirsk Institute (Russia)** S Eidelman  
**NCSL (US)** Geoff Koch  
**Orsay Laboratory (France)** Anne-Marie Lutz  
**PSI Laboratory (Switzerland)** P-R Kettle  
**Saclay Laboratory (France)** Elisabeth Locci  
**Science and Technology Facilities Council (UK)** Peter Barratt

**Produced for CERN by IOP Publishing Ltd**  
 IOP Publishing Ltd, Dirac House, Temple Back, Bristol BS1 6BE, UK  
 Tel +44 (0)117 929 7481

**Publisher** Jo Nicholas  
**Art director** Andrew Giaquinto  
**Production editors** Lizi Brown, Jesse Karjalainen  
**Technical illustrator** Alison Tovey  
**Advertising manager** Ed Jost  
**Recruitment advertisement manager** Moo Ali  
**Recruitment and classified sales** Jordan Jurgiel, Sonia Nardo  
**Recruitment and classified sales North America** Mark Gaglione  
**Advertisement production** Jayne Boulton  
**Marketing executive** Anastasia Ireland

**Advertising**  
 Tel +44 (0)117 930 1026 (for UK/Europe display advertising),  
 +1 215 627 0880 (for North American display advertising), or  
 +44 (0)117 930 1027 (for recruitment advertising);  
 e-mail sales@cerncourier.com; fax +44 (0)117 930 1178

**General distribution** Courier Adressage, CERN, 1211 Geneva 23, Switzerland. E-mail courier-adressage@cern.ch  
 In certain countries, to request copies or to make address changes, contact:

**China** Keqing Ma, Library, Institute of High Energy Physics, PO Box 918, Beijing 100049, People's Republic of China. E-mail keqingma@mail.ihep.ac.cn  
**Germany** Veronika Werschner, DESY, Notkestr. 85, 22607 Hamburg, Germany. E-mail desypr@desy.de  
**Italy** Loredana Rum or Anna Pennacchietti, INFN, Casella Postale 56, 00044 Frascati, Rome, Italy. E-mail loredana.rum@inf.it  
**UK** Sue Dickenson, Chadwick Library, STFC, Daresbury Science & Innovation Campus, Daresbury Laboratory, Warrington, Cheshire WA4 4AD. E-mail s.m.dickenson@dl.ac.uk  
**US/Canada** Published by Cern Courier, 6N246 Willow Drive, St Charles, IL 60175, US. Periodical postage paid in St Charles, IL, US. Fax 630 377 1569. E-mail vosses@aol.com  
 POSTMASTER: send address changes to: Creative Mailing Services, PO Box 1147, St Charles, IL 60174, US

**Published by** European Organization for Nuclear Research, CERN, 1211 Geneva 23, Switzerland. Tel +41 (0) 22 767 61 11  
 Telefax +41 (0) 22 767 65 55

**Printed by** Warners (Midlands) plc, Bourne, Lincolnshire, UK

© 2008 CERN ISSN 0304-288X

# CERN COURIER

VOLUME 48 NUMBER 3 APRIL 2008



The science of sandcastles p10

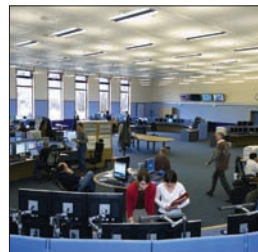

Controlling the LHC p20

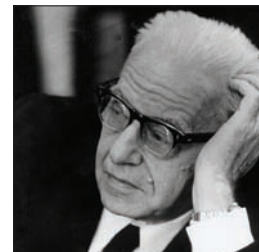

Celebrating Mięśowicz p34

## News

5

*ATLAS puts last piece in puzzle...while LHCb gets data collection on track. Teams mark final fitting of warm magnets. ICFA calls for stability in science funding. UA1 magnet sets off for a second new life. New limits constrain the WIMPs. Brookhaven laboratory develops stochastic cooling for RHIC.*

## Sciencewatch

10

## Astrowatch

11

## CERN Courier Archive

12

## Features

### QCD: string theory meets collider physics

13

*Two fields of physics met at the 2007 DESY theory workshop.*

### Control systems for big physics reach maturity

16

*The 11th ICALPECS conference looked at projects around the world.*

### Under control: keeping the LHC beams on track

20

*Pierre Charrue describes the infrastructure to ensure correct operation.*

### Detector controls for LHC experiments

24

*Wayne Salter explains the basis for a new collaborative approach.*

### Trieste workshop puts a RICH variety on show

27

*An international meeting confirms the vitality of the technique.*

## Recruitment

29

## Faces and Places

32

## Bookshelf

37

## Viewpoint

38

**IOP Publishing**



**Cover:** The last big piece for the ATLAS detector sets off on its final journey to the experiment's underground cavern (p5).

# The Future. Most exciting.



© BICOM\_09507\_S\_02 03.2008

At Oerlikon Leybold Vacuum we not only endeavour to support new research results - we strive to promote them.

For this, we examine all the possibilities of improving our products until we find a decisive and entirely new way. How many ways there are, has been proven by Leybold Vacuum time and time again: through our innovative vacuum solutions. They are the expression of our vision to achieve progress through constant innovation.

Numerous maintenance-free vacuum components and systems like magnetically levitated turbomolecular pumps, sputter ion pumps and cryogenic pumps, combined with modern dry fore-vacuum pumps and reliable transmitter technology, are available to support demanding high vacuum and ultra-high vacuum projects in the area of industrial and university research.

Contact us - we are engineering our customer's success.

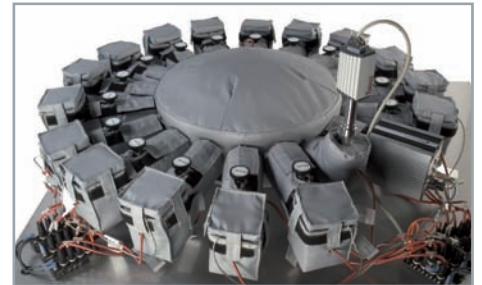

*Image detail: UHV vacuum chamber with 16 components in heating jackets connected*

Oerlikon  
Leybold Vacuum GmbH  
Bonner Strasse 498  
D-50968 Cologne

T +49 (0) 221-347-0  
F +49 (0) 221-347-1250  
info.vacuum@oerlikon.com

[www.oerlikon.com](http://www.oerlikon.com)

**oerlikon**  
leybold vacuum

## LHC EXPERIMENTS

# ATLAS puts last piece in puzzle...

The ATLAS collaboration celebrated lowering the final large piece of the detector into the underground cavern on 29 February. The event marked a major milestone for the muon spectrometer group, as well as the final installation of large detector components below ground.

ATLAS is the world's largest general-purpose particle detector, measuring 46 m long, 25 m high and 25 m wide. It weighs 7000 tonnes and consists of around 100 million sensors that will measure particles produced in collisions in the LHC. The first major piece was installed in 2003 and since then, many detector elements have journeyed down the 100 m shaft into the cavern. This last piece completes the gigantic puzzle.

Modest in scale compared with the large 25 m diameter muon spectrometer wheels, this last element is one of two pieces known as the "small" wheels, the first having descended into the cavern two weeks earlier. Both small wheels measure 9.3 m in diameter and weigh 100 tonnes, including massive shielding elements. Unlike the large wheels, whose assembly was completed in the



*The small wheel made the 100 m journey into the underground ATLAS experimental cavern, landing safely at the bottom in an hour and a half.*

cavern, they were assembled on the surface on CERN's main site and then transported slowly and carefully by road transport across to the ATLAS cavern at Point 1 on the LHC ring.

The whole muon spectrometer system would cover an area equivalent of three football fields, and includes 1.2 million independent electronic channels. The

small wheels, which complete the system, are closest to the interaction point in the small-angle region, next to the calorimeter and the two end-caps of the toroid magnet. Each small wheel consists of two discs placed one against the other and slotted together with a central cylindrical component. One wheel provides shielding, which will absorb particles other than muons, while the other acts as the support for the detection chambers. Three of the four different kinds of muon chamber found in ATLAS are fitted onto the small wheels, including trigger chambers and two types of precision chamber – cathode strip chambers and monitored drift tubes – which will allow the muon tracks to be reconstructed with a precision of 10  $\mu\text{m}$ .

The ATLAS muon-spectrometer group comprises 450 physicists from 48 institutions, and includes members from China, France, Germany, Greece, Israel, Italy, Japan, the Netherlands, Russia and the US. They have spent more than a decade developing, planning and constructing the ATLAS muon spectrometer, with the shielding elements constructed in Armenia and Serbia.

## ...while LHCb gets data collection on track

On 8 February, the LHCb collaboration succeeded in extracting data from an almost-complete set of detectors. The exercise was an important test run to flag up any problems in the experiment before the next commissioning week in March.

Sixty electronic boards that read out information from the triggered events were used during the tests, collecting data at a

frequency of 100 Hz. As not all of the boards have been installed or commissioned yet, this represents only around 20% of the data that the detectors are capable of generating.

There were also indications that cosmic tracks were recorded in the calorimeter system and the outer tracker. Because LHCb is set up with the detectors aligned in vertical planes, it is not easy to record the tracks of

cosmic rays. However, there are rare cosmic rays that travel almost horizontally at a rate of a fraction of a hertz through LHCb. The main goal of the commissioning week in March is to collect cosmic events in all detectors together. This will allow an initial alignment in time of all of the components and provide some tracks to be used by the reconstruction and alignment teams.

### Sommaire

ATLAS: on a fini le puzzle	5	De nouvelles limites pour les WIMPs	8
LHCb prêt pour la collecte de données	5	Brookhaven: nouveau refroidissement stochastique pour RHIC	9
Les équipes fêtent l'installation des aimants chauds	6	Des lasers femtosecondes pour dorer l'aluminium	10
L'ICFA appelle à plus de stabilité dans les financements	6	Hubble et Spitzer découvrent une galaxie à	
L'aimant UA1 commence une deuxième vie	7	une distance record	11

## LHC NEWS

# Teams mark final fitting of warm magnets

The LHC is well known for its hundreds of superconducting magnet assemblies, but it will also use 154 normally conducting “warm” magnets. On 19 February, a celebration took place at CERN to mark the installation of the last of these magnets, which play a key role in shaping the course of the proton beams.

The LHC consists of a number of arcs with straight sections in between, where the magnetic intensity required to bend the beams is not as high as elsewhere, and warm magnets can be used in these places. One advantage is their robustness when exposed to radiation, which is important, for example, in the two long straight sections where collimators clean the beam by removing particles far from the central orbit. Using superconducting magnets here would be problematic, as secondary particles produced in the collimators could reach the magnets and cause a quench. Warm magnets also have the advantage of being more affordable than superconducting magnets and are easier to make and install, owing to their comparative simplicity. Nearly all of the



From left to right: Philippe Lebrun, head of the Accelerator Technology Department; Willi Kalbreier, former Normal Conducting Magnet section leader; Karl Hubert Mess, former Magnets and Electric Systems group leader; and Lucio Rossi, Magnets, Cryostats and Superconductors group leader.

warm magnets were made specially for the LHC and travelled great distances to reach CERN: 48 magnets have come from TRIUMF, Vancouver; 40 from the Institute for High Energy Physics in Protvino, near Moscow;

and 65 from the Budker Institute of Nuclear Physics in Novosibirsk, Russia. Only one magnet had a previous existence. Originally built for the ISR in the 1970s, it is now being used in the ALICE experiment.

## RESOURCES

## ICFA calls for stability in science funding

The International Committee for Future Accelerators (ICFA) has issued a statement on the need for continuous and stable funding for large international science projects, such as the proposed International Linear Collider. This statement is a reaction to recent cuts in the science budgets of the UK and the US, and addresses governments and science funding agencies around the world.

In the statement, ICFA expresses its deep concern about the recent decisions in the UK and the US on spending for long-term international science projects. It points out that “frontier science relies increasingly on stable international partnerships, since the scientific and technical challenges can only be met by enabling outstanding men and women of science from around the world to collaborate, and by joining forces to provide the resources they need to succeed”.

The statement continues: “A good example is the proposed International Linear Collider. In order to advance the understanding of the innermost structure of matter and the early development of the universe, several

thousand particle physicists and accelerator scientists around the world, during the past 15 years, have co-ordinated their work on developing the technologies necessary to make a linear collider feasible.

“In view of these tightly interlinked efforts, inspired and driven by the scientific potential of the linear collider, the sudden cuts implemented by two partner countries have devastating effects. ICFA feels an obligation to make policy makers aware of the need for stability in the support of major international science efforts. It is important for all governments to find ways to maintain the trust needed to move forward international scientific endeavours.”



# VACUUM VALVES

[www.vatvalve.com](http://www.vatvalve.com)



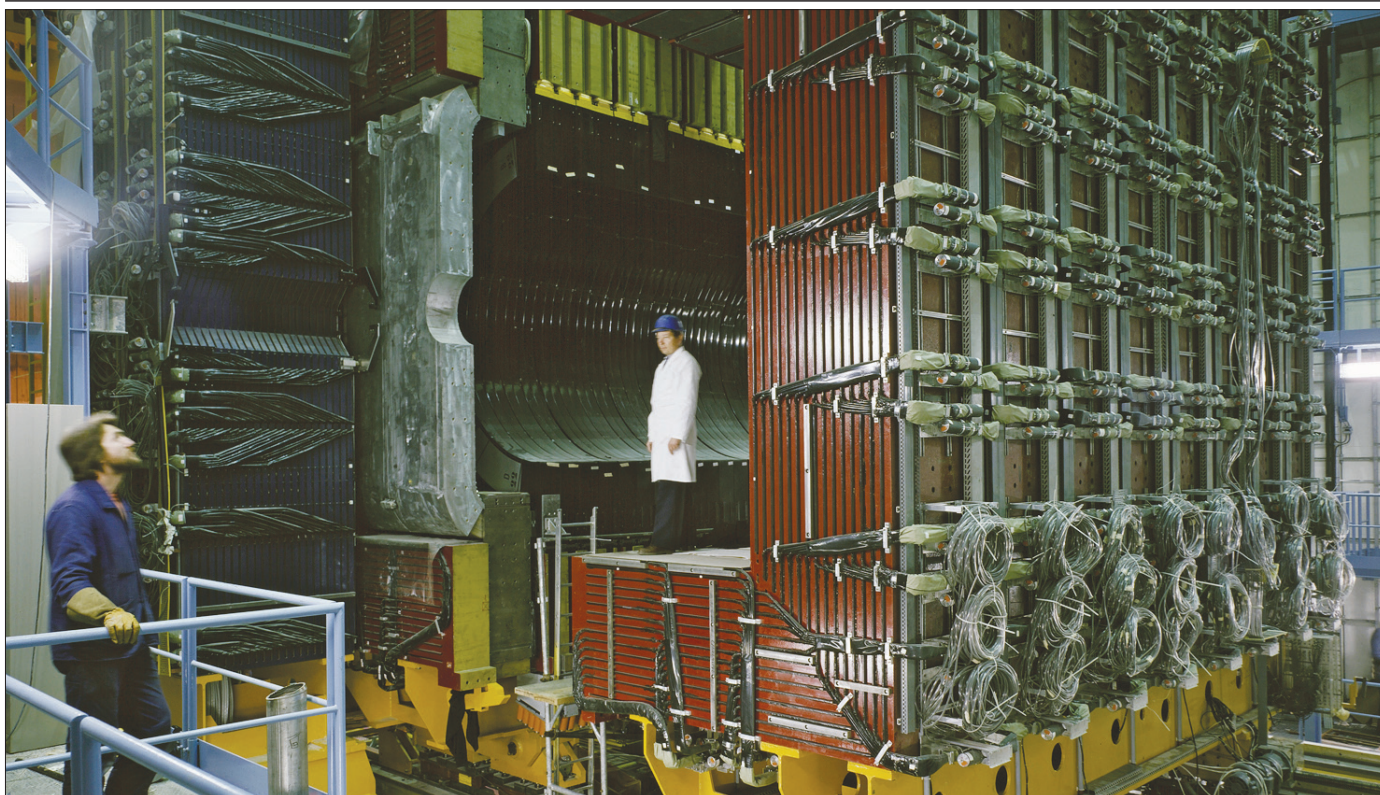

The UA1 magnet during assembly in 1980. The red sections of the return yoke and the end of the aluminium coils are clearly visible.

CERN

## UA1 magnet sets off for a second new life

A magnet built originally for the UA1 detector at CERN and later used by the NOMAD experiment has set sail for a new life in Japan. Thirty-five containers carrying 150 pieces departed CERN in the last two weeks of January, with the last components – the large aluminium coils – following in March.

In 2005, at the request of European physicists involved in the international Tokai to Kamioka (T2K) long-baseline neutrino experiment, CERN decided to donate the former UA1 magnet, its coils and other equipment to KEK in Japan. For T2K, which will start in autumn 2009, the Japan Proton Accelerator Research Complex at Tokai will use a 40 GeV proton beam to produce an

intense low-energy neutrino beam directed towards the Super-Kamiokande neutrino observatory 300 km away.

Built in 1979, the UA1 magnet was later given a second lease of life with the NOMAD neutrino-oscillation experiment at CERN. Since NOMAD was dismantled in 2000, the magnet has been stored in the open air, exposed to the elements, at CERN's Prévessin site. All the parts were cleaned, polished and repainted before shipment to Japan, including a general overhaul in readiness for transport. However, many of the parts could not be transported in one piece, especially by sea, so much of the equipment had to be dismantled before being loaded into containers.

The general overhaul, and other work needed to prepare the parts for shipping, took almost a year. On 14 January, one by one, 35 sea-going containers began their long journey to Tokai, 60 km north of Tokyo. They first travelled by train to Antwerp, from where they were bound for the port of Hitachinaka via Pusan, in South Korea. The final, and largest, component – consisting of the four very fragile coils – was scheduled to leave CERN at the end of March. With a height of 4.75 m, the aluminium coils weigh close to 40 tonnes and have been packaged into two 1.70 m wide consignments for transport as an exceptional lorry load to Basel, then by barge to Rotterdam to set sail for Japan.

Les physiciens des particules du monde entier sont invités à apporter leurs contributions aux *CERN Courier*, en français ou en anglais. Les articles retenus seront publiés dans la langue d'origine. Si vous souhaitez proposer un article, faites part de vos suggestions à la rédaction à l'adresse [cern.courier@cern.ch](mailto:cern.courier@cern.ch).

*CERN Courier* welcomes contributions from the international particle-physics community. These can be written in English or French, and will be published in the same language. If you have a suggestion for an article, please send your proposal to the editor at [cern.courier@cern.ch](mailto:cern.courier@cern.ch).

## DARK MATTER

# New limits constrain the WIMPs

The Chicagoland Observatory for Underground Particle Physics (COUPP) has tightened constraints on the spin-dependent properties of the weakly interacting massive particles (WIMPs) that are candidates for dark matter. At the same time, the Cryogenic Dark Matter Search (CDMS) has announced results that set the world's best constraints on the spin-independent properties of dark-matter candidates.

The COUPP experiment is an intriguing new application of the bubble chamber technique, located 100 m underground in the tunnel for the Neutrinos at the Main Injector project at Fermilab. It uses a small quartz vessel at room temperature filled with 1.5 kg of superheated iodotrifluoromethane ( $\text{CF}_3\text{I}$ ), a refrigerant that is often used in fire extinguishers. Two effects reveal the formation of bubbles in the chamber: the sound and pressure rise caused by their growth, and the changes in their appearance monitored by two CCD cameras. Once they reach a millimetre or so in size, they trigger the system to record photographs of the chamber. The chamber then goes through a cycle of compression and decompression to bring it back to a bubble-free, superheated state.

The innovative detector offers several advantages in the search for WIMPs, the most important being that the superheated liquid can be tuned to respond only to particles with large stopping power. This means that it can be set up in such a way that muons, gamma-rays, X-rays, and other kinds of common background, deposit too little energy to form bubbles. When the detector is searching for WIMPs, the threshold for bubble nucleation is typically above 50 keV/ $\mu\text{m}$ .

The team operated the chamber continuously from December 2005 to December 2006, with around 100 s between expansions. Although the chamber is only a prototype, the first results from COUPP, combined with the findings of other dark-matter searches, contradict the claims for the observation of WIMPs by the Dark Matter experiment (DAMA) in Italy. Previous experiments had already constrained the possibility that the DAMA observations

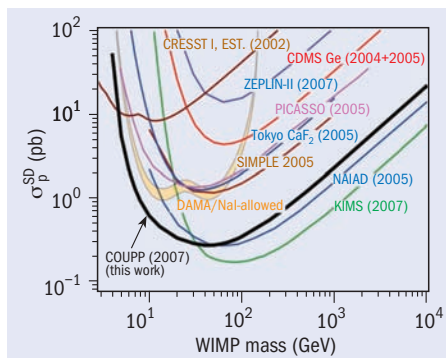

COUPP's improved limits on the spin-dependent (pure) proton-WIMP interaction cross section (expressed in picobarns) versus WIMP mass. Couplings above the line would have produced signals above observed backgrounds and are excluded to a 90% confidence level. Limits from other experiments are also shown, as well as the region favoured to explain the DAMA result.

result from dark-matter, spin-independent interactions and COUPP has now ruled out the last region of parameter space allowed for a spin-dependent explanation (Behnke *et al.* 2008). If the DAMA result had been due to spin-dependent WIMPs, then COUPP should have found hundreds of examples, but instead it found none above background.

The COUPP team now aims to improve the sensitivity of the experiment by increasing the amount of liquid in the detector from 1 l to 30 l, and it expects to start testing the larger chamber soon. The experiment could move to a deeper tunnel to reduce the background from cosmic radiation even further.

Meanwhile, the CDMS collaboration announced the world's most stringent limits on how often dark-matter particles interact with ordinary matter and on how heavy they are, in particular in the theoretically favoured mass range of more than 40 times the proton mass. The CDMS experiment, situated in the Soudan Underground Laboratory, Minnesota, is now running with all of its detectors – 19 germanium detectors of 250 g each and 11 silicon detectors of 100 g. The detectors operate at 50 mK and each consists of a disc some 7.5 cm in diameter and 1 cm thick.

The new results, announced at the Dark

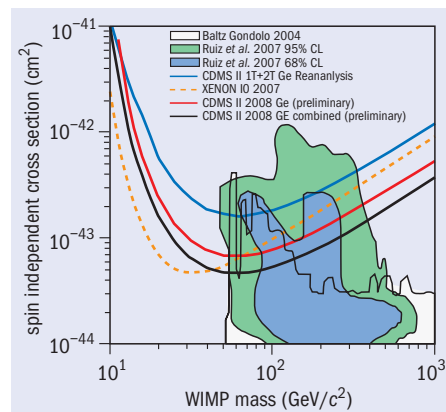

The CDMS limits on how often dark-matter particles interact with ordinary matter and how heavy they are, in particular in the theoretically favoured mass range of more than about 40 GeV/ $c^2$ . The regions excluded are those above the solid lines. The black line is the most stringent limit.

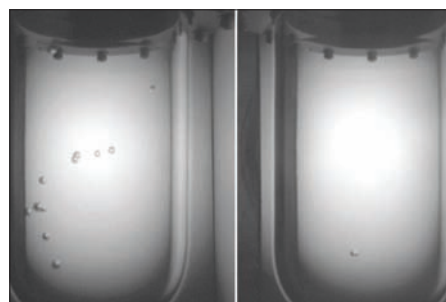

Left: a sequence of bubbles created by multiple scattering of a neutron in COUPP. WIMPs are expected to produce a single bubble as shown on the right. (Courtesy COUPP collaboration.)

Matter 2008 conference in Marina del Ray, California, are based on the analysis of data collected from 15 germanium detectors between October 2006 and July 2007 (Ahmed *et al.* 2008). The analysis resulted in no dark-matter events and excludes the parameter space for WIMPs with masses above 42 GeV/ $c^2$ .

### Further reading

Z Ahmed *et al.* 2008 [http://cdms.berkeley.edu/conference\\_talks\\_links/CDMS\\_5Tpreprint\\_080222.pdf](http://cdms.berkeley.edu/conference_talks_links/CDMS_5Tpreprint_080222.pdf).

E Behnke *et al.* 2008 *Science* **319** 933.



## ACCELERATORS

# Brookhaven laboratory develops stochastic cooling for RHIC

Accelerator physicists at Brookhaven National Laboratory have developed a way to apply the technique of stochastic cooling to the beams in the Relativistic Heavy Ion Collider (RHIC). This is the first time that the technique for concentrating a particle beam has been used in a machine where the particles are bunched. The results of the tests in 2007, which offer a “fast track” to upgrading the luminosity at RHIC, were presented in February at the Quark Matter 2008 meeting in Jaipur.

RHIC circulates two beams of heavy ions moving in opposite directions in two separate rings, each beam being in bunches of more than  $10^9$  ions per bunch. With the high electrical charges of the heavy ions, the particles spread out (“heat up”) while the beams are stored during colliding-beam operations, and ultimately they become lost. This reduces the collider’s luminosity and, in consequence, the probability for collisions. It also necessitates beam “cleaning” to avoid particles diverging into the superconducting magnets and causing them to quench.

One way to overcome this effect is to direct the particles back on track, which is just what happens with stochastic cooling. Invented by Simon van der Meer at CERN, the technique was applied in the 1980s to accumulate and cool antiprotons prior to injection and acceleration in the SPS. This led to the Nobel Prize for Physics for van der Meer and Carlo Rubbia, when the W and Z particles were discovered in proton–antiproton collisions in the SPS. However, later tests at both the SPS and Fermilab’s Tevatron showed that there are complications when applying stochastic

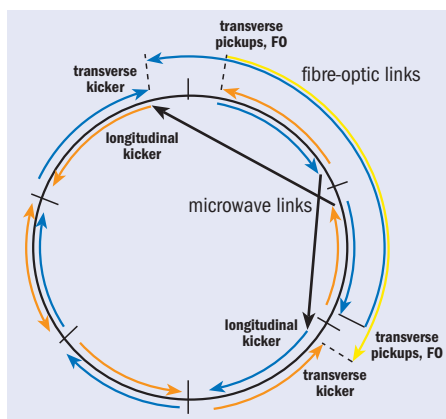

*Schematic layout of “pickups” and “kickers” – and the fibre-optic and microwave links between the two – when longitudinal and transverse stochastic cooling are implemented for both beams at RHIC.*

cooling to a machine where the particles are already in a bunched beam.

The technique relies on measuring the random fluctuations in the beam shape and size – hence the name “stochastic”, which is derived from statistics and means random. The measurements are made at one point on the accelerator by devices that generate signals proportional to how far the particles are straying from their ideal positions.

At RHIC these devices send the signals via fibre-optic or microwave links to a position ahead of the speeding beam, where electric fields are generated to kick the charged particles back towards their ideal positions. This results in more tightly squeezed (“cooler”) ion bunches. The signals stay ahead of the beam by taking one of two shortcuts: either

travelling from one point to another across the circular accelerator or backtracking along the circle to meet the speeding beam roughly halfway round on its next pass.

So far, the team at RHIC has tested stochastic cooling in the longitudinal direction – along the direction of the beam – in one of RHIC’s two rings. Longitudinal cooling compensates for the ion bunches’ tendency to lengthen as they circulate. This improvement has already increased RHIC’s heavy-ion collision rate by 20%. The team has now installed equipment to implement the longitudinal cooling system in the second of RHIC’s rings.

The aim is also to install a system for transverse cooling in one of the beams before 2009. This would allow tests of significantly increased luminosity in gold–gold collisions in RHIC.

This successful demonstration of stochastic cooling provides an alternative way to increase collision rates that is less costly and quicker than other methods considered for RHIC II, electron cooling in particular, which would cost \$95 m. Simulations suggest that stochastic cooling, together with other improvements, could increase the luminosity for gold–gold collisions to some  $50 \times 10^{26} \text{ cm}^{-2} \text{ s}^{-1}$ , or about 70% of the design goal for RHIC II. The team should be able to complete the system for stochastic cooling with an extra \$7 m. According to Steven Vigdor, Brookhaven Associate Laboratory director for nuclear and particle physics, the laboratory hopes to implement the full stochastic cooling system by 2011.

Motion in Vacuum



UHV  
Leakvalve

VSE

VACUUM  
TECHNOLOGY

A-6890 LUSTENAU (AUSTRIA), Sandstr. 29

Tel: +43 (0) 55 77 - 82 6 74

Fax: +43 (0) 55 77 - 82 6 74 - 7

e-mail: office@vseworld.com

www.vseworld.com

Compiled by Steve Reucroft and John Swain, Northeastern University

## Femtosecond lasers turn the colour of aluminium to gold

The old alchemist's dream of turning base metals into gold is still just a dream, but a new technology allows metals to take on different colours without any need for a coating of any kind. AY Vorobyev and Chunlei Guo of the Institute of Optics at the University of Rochester in New York have shown that femtosecond laser pulses can produce nanostructures that make aluminium appear gold, black, or grey, irrespective of the viewing angle.

Other colours can be made, but with some dependence on the angle from which the surface is viewed. It is a low-cost procedure and could find a range of applications.

### Further reading

AY Vorobyev and C Guo 2008 *Applied Physics Letters* **92** 041914.

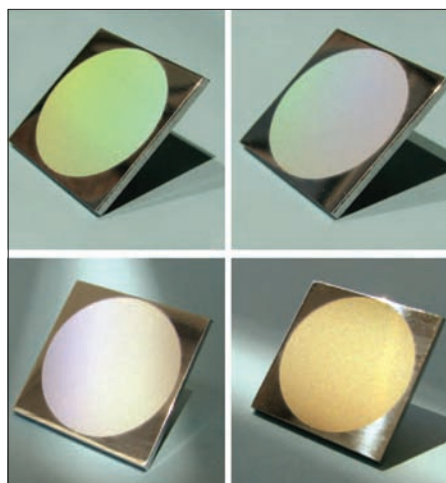

The same 25x25 mm piece of aluminium exhibits different colours depending on the viewing angle.

## The stability of sandcastles

Sandcastles are remarkably stable despite changes in the water content of the wet sand that they comprise, but it is only now that there is some solid understanding of why this is so. M Scheel of the Max Planck Institute for Dynamics and Self Organization in Göttingen, and colleagues, took X-ray cross sections of piles of wet glass beads with varying amounts of liquid contained within.

As more water is added, the capillary forces that hold moist beads together weaken but at the same time reach more surfaces, so that the two effects counterbalance each other over a large range of wetnesses.

Consequently, this makes the stiffness of



Properties of sand help sandcastles to stay up. (Courtesy Yory Frenklakh/Dreamstime.com.)

wet sand largely independent of the amount of water that is present.

### Further reading

M Scheel et al. 2008 *Nature Materials* **7** 189.

## Dynamism for 3D holograms

A new, updatable holographic display may open the window to new applications of 3D imaging. Savaş Tay of the University of Arizona, and colleagues have developed a photorefractive polymer that

can be written and updated in minutes with a hologram and used to produce a 10 x 10 cm 3D image – the largest photorefractive display ever made. It can be viewed for hours without refreshing and is completely erasable and rewritable with the appropriate lasers.

### Further reading:

S Tay et al. 2008 *Nature* **451** 694.

## Researchers create self-healing rubber

It may sound like something out of science fiction, but Philippe Cordier and colleagues at the Ecole Supérieure de Physique et Chimie Industrielles in Paris have made a new sort of rubber that can mend itself after being torn.

The idea is to have the cross linking done with hydrogen bonds and not, as is usually the case, with covalent bonds. If the rubber tears, the new ends have active hydrogen bonds, which will re-attach if the new surfaces are simply just pressed together.

This self-reparation takes place without glueing or heating, and is a genuinely novel evolution in making self-healing materials.

### Further reading

P Cordier et al. 2008 *Nature* **451** 977.

## Languages do not evolve smoothly

Researchers in the UK have found evidence that languages evolve in fits and bursts rather than smoothly over time. Quentin Atkinson of the University of Reading and colleagues have constructed evolutionary linguistic trees of Bantu, Indo-European and Austronesian languages, with the lengths of branches representing lexical divergence (the number of different words) and nodes representing splits where new language formed.

The study tested the hypothesis that if lexical divergence evolved smoothly, unaffected by the appearance of new languages, then the lengths of branches would be unaffected by the presence of nodes. However, this does not seem to be the case, because the team found that each split triggers a burst of change, and that such changes account for between a tenth and a third of all differences between languages.

Such large jumps might be attributed to idiosyncrasies of the members of groups that start off a new language or to a wish for a group speaking a new language to distinguish itself sharply from another group.

### Further reading

Q D Atkinson et al. 2008 *Science* **319** 588.

## Astronomers find galaxy at record distance

The joint forces of NASA's Hubble and Spitzer space telescopes have identified a source that is likely to be the most distant galaxy known to date. If confirmed, this discovery will be a new milestone on the path towards the detection of the earliest galaxies emerging from the dark ages.

In astronomy, looking far is looking in the past and thus the most distant galaxies are seen as they were when the universe was only about 1000 million years old. This is roughly the time when the universe became re-ionized by the collective light of early galaxies and marks the end of the "dark ages". This period was dark not only because stars and galaxies were just starting to form but also because the universe was pervaded by cold clouds of gas that were effective in absorbing radiation at wavelengths below the photoionization threshold of hydrogen at 91.2 nm. This leads to a break in the spectrum of the most distant galaxies, which appears shifted from the ultraviolet to the infrared because of the cosmological redshift. For an object at a redshift of  $z = 7$ , this "Lyman break" would be shifted by a factor of  $1 + z$ , from 91.2 nm to 730 nm. A source at such a high redshift should thus be detectable in the infrared, while remaining unseen in the visible range. This is the signature for identifying the most distant galaxies.

Strangely, the best places to search these extreme sources are not necessarily the most empty regions of the night sky (*CERN Courier* November 2006 p10), but can also be the bright areas covered by huge clusters



*This Hubble image shows the galaxy cluster Abell 1689, used as a cosmic lens to magnify the light of the most distant galaxies. (Courtesy NASA/ESA/JHU (L Bradley, H Ford)/UCSC (R Bouwens, G Illingworth).)*

of galaxies. The global cluster mass deforms space-time and provides a natural lens that magnifies the light received from galaxies located far beyond the cluster. Furthermore, a detailed mapping of this gravitational lensing effect shows the places where the magnification of remote galaxies would be maximum and thus tells astronomers where to search. Using this technique, a team of astronomers announced the discovery of a source at a redshift of 10 (*CERN Courier* May 2004 p13), but this detection turned out to be spurious.

A highly reliable candidate for a galaxy at

a redshift of more than seven has now been detected through the galaxy cluster Abell 1689 in a deep exposure with the Hubble Space Telescope. The relatively nearby cluster (redshift  $z = 0.18$ ) magnifies the light of the remote galaxy by almost a factor ten. This source, found by Larry Bradley from the Johns Hopkins University in Baltimore and colleagues, is much brighter than other high-redshift candidates and therefore the detection of the Lyman break is more significant. The source was unseen with the Hubble Advanced Camera for Surveys at wavelengths shorter than 850 nm, but is detected with high significance ( $8\sigma$ ) at  $1.1 \mu\text{m}$  by the Near Infrared Camera and Multi-Object Spectrograph, while becoming dimmer towards longer wavelengths. The authors claim only a star-forming galaxy at a redshift of  $7.6 \pm 0.4$  can reasonably fit these properties.

Subsequent observations with the infrared Spitzer Space Telescope confirm the presence of the source and constrain better the nature of the object. The observations suggest a galaxy with a mass of about 3000 million times that of the sun in the form of stars younger than about 300 million years. This is consistent with the expectations for such early galaxies, but final confirmation of the discovery will require a redshift determination with near-infrared spectroscopy.

### Further reading:

L D Bradley *et al.* 2008 *ApJ* in press  
<http://arxiv.org/abs/0802.2506>.

### Picture of the month

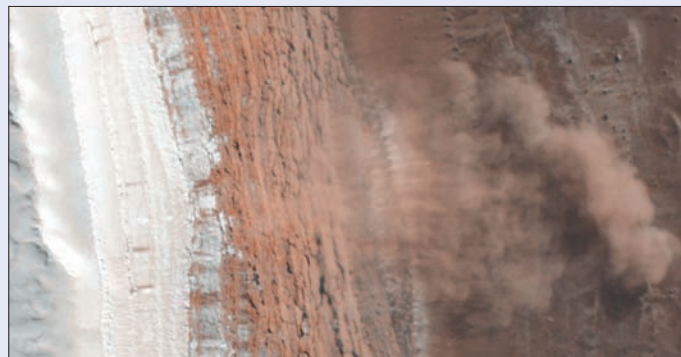

This amazing view of Mars has captured an avalanche, or debris fall, in action. It was taken on 19 February by the High Resolution Imaging Science Experiment camera on NASA's Mars Reconnaissance Orbiter. It shows the edge of the dome of layered deposits on Mars' north pole.

The top part of the scarp, to the left of the image, is covered with bright (white) carbon dioxide frost. The avalanche is made of an ice-dust mixture that detached from the upper cliff and cascaded to the gentler slopes 700 m below. The dust clouds are about 180 m across and their shadows are projected on the cliff by the sunlight coming from the upper right. (Courtesy NASA/JPL-Caltech/University of Arizona.)

# CERN COURIER ARCHIVE: 1965

A look back to *CERN Courier* vol. 5 April 1965, compiled by Peggie Rimmer

## COMPUTING

# CERN's new powerful computer

The Control Data 6600 Computer, the most powerful computer available, was ordered by CERN in January 1964 and has now arrived and been installed. As so often with new machines, and computers are no exception, certain delays have been encountered on the schedule originally planned, but the 6600 "hardware" has now been installed and all that remains is for the final "software" (operating system) to be delivered. The computer was flown to Geneva on Thursday 14 January and the CERN transport section unloaded the plane and brought the whole machine to a temporary storage in the East experimental hall of the PS. There it stayed, on the trucks, until the Friday morning, when the task of unloading and unpacking it began. At the end of the day the computer was finally placed in the new computer room and the assembly work was well under way.

The installation of the machine continued all weekend following its delivery: all the cables were connected by the Monday morning and power was switched on. From that moment the team of engineers worked 24 hours per day commissioning the equipment and then, on the Thursday, the first Fortran programme was successfully compiled (converted into the language used by the machine itself). After that, more and more programmes were run to find possible errors in the machine.

Programming will be done in CERN FORTRAN, a version of Fortran chosen to be compatible with many existing versions of the Fortran language. The operating system of the computer is completely different from that of the IBM 7090 and has not yet been delivered. Until it is, all work that is processed on the 6600 has to be run under the more primitive Chippewa system, an interim system that arrived with the Fortran compiler on 5 April. CERN programmes can be processed on this system, making the 6600 available for general use without waiting for the final CERN system, SIPROS. When SIPROS is delivered it will be modified by the Programming Section to include several other features, such as tape labelling and error procedures, before



*General view of the new 6600 computer room at CERN. The computer itself is in the centre background, behind the control console. To the left are some of the tape units, and two of the high-speed printers. On the right, at the back, are the two disc files. The new 6600 room has been built alongside the old 7090 room, and between it and the programmers' area is an "in/out wall" which allows the incoming work to be passed to the card-reader operator and the results to be delivered back to the programmer through pigeonholes.*

its general use can begin. For those initiated in computer nomenclature, it is worth noting that the 6600 comprises 128K of 60-bit central-memory words, with 10, effectively independent, peripheral processors of 4K words each – these latter controlling all the data transfers in the whole system. There are 12 units for one-inch magnetic tape and four for half-inch tape, two discs of 7.5 million 60-bit words each, three 1000 line/minute printers, a card reader, a card punch and a console. The computer is expected to be capable of about 15 times the throughput provided by the CERN 7090, together with the possibility of quicker input and turnaround for the user and the connection on-line of many devices such as the HPD (Hough–Powell device for measuring bubble chamber photographs), IEPs (instruments pour l'évaluation des photographies), spark-chamber experiments, typewriters and displays.

● Compiled from the article on p53.

## COMPILER'S NOTE

Over the years, the increasing data volumes and data rates of high-energy physics experiments have constantly pushed computing and networking technologies to and often beyond their limits. Also the changing size and sociology of the experiments have had an outcome that could only have been foreseen with 20:20 hindsight – the World Wide Web, developed to allow collaborators distributed around the globe to share information over the internet.

At the LHC, the experimental teams contain thousands of collaborators and the detectors will generate several gigabytes of data per second (tens of petabytes per year). To exploit the scientific potential of the machine fully, the resources of many computing centres are needed to provide sufficient storage, plus computational and network capacity. CERN became an early leader in grid infrastructure projects to allow computer power and data-storage capacity to be shared over the internet. The European DataGrid test-bed in 2001 was followed, in 2003, by the LHC Computing Grid, leading to the current multisite Enabling Grids for E-science project, already encompassing earth sciences, high-energy physics, bioinformatics and astrophysics.

# QCD: string theory meets collider physics

The 2007 DESY theory workshop was devoted to an emerging interplay between two established research areas, quantum chromodynamics and string theory.



Juan Maldacena from the Institute for Advanced Study at Princeton, left, in conversation with Lance Dixon. (Courtesy Marta Mayer/DESY.)

With the title Quantum Chromodynamics – String Theory meets Collider Physics, the 2007 DESY theory workshop brought together a distinguished list of speakers to present and discuss recent advances and novel ideas in both fields. Among them was Juan Maldacena from the Institute for Advanced Study, Princeton, pioneer of the interrelationship between gauge theory and string theory, who also gave the Heinrich Hertz lecture for the general public.

From a dynamical point of view, quantum chromodynamics (QCD), the theory of strong interactions, represents the most difficult sector of the Standard Model. Mastering the complexities of strong interactions is essential for a successful search for new physics at the LHC. In addition, the relevance of the QCD phase transition for the early evolution of our universe has ignited an intense interest in heavy-ion collisions, both at RHIC in Brookhaven and at the LHC at CERN. The QCD community is thus deeply engaged in investigations to further our understanding of QCD, to reach the highest accuracy in its theoretical predictions and to advance existing computational tools.

String theory, initially considered a promising theoretical model for strong interactions, was long believed incapable of capturing, in detail, the correct high-energy behaviour. In 1997, however, Maldacena overcame a prominent obstacle for applications of string theory to gauge physics. He proposed describing strongly coupled

four-dimensional (supersymmetric) gauge theories through closed strings in a carefully chosen five-dimensional background. In fact, equivalences (dualities in modern parlance) between gauge and string theories emerge, provided that the strings propagate in a five-dimensional space of constant negative curvature. Such a geometry is called an anti deSitter (AdS) space and the duality involving strings in an AdS background became known as AdS/CFT correspondence, where CFT denotes conformal field theory. If the duality turns out to be true, string-theory techniques can give access to strongly coupled gauge physics, a regime that only lattice gauge theory has so far been able to access. Though a string theory dual to real QCD has still to be found, AdS/CFT dualities are beginning to bring string theory closer to the “real world” of particle physics.

With the duality conjecture as its focus, the DESY workshop covered the full spectrum of research topics that have entered this interdisciplinary endeavour. Topics ranged from the role of QCD in the evaluation of experimental data and in Monte Carlo simulations to string theory calculations in AdS spaces.

To begin with the more practical side, QCD clearly dominates the daily analysis of data from RHIC, HERA at DESY, and Fermilab’s Tevatron. Tom LeCompte of Argonne presented results from the Tevatron, and Uta Klein of Liverpool looked at what we have learned ▷

from HERA. The results relating to parton densities will be of utmost importance for measurements at the LHC, not least in the kinematic region of small  $x$ , which was among the highlights of HERA physics. Diffraction – one of the puzzles for the HERA community – continues to demand attention at the LHC, in particular as a clean channel for the discovery of new physics, as Brian Cox of the University of Manchester explained.

Monte Carlo simulations represent an indispensable tool for analysing experimental data, and existing models need steady improvement as we approach the new energy regime at the LHC. Gösta Gustafson of Lund and Stefan Gieseke of Karlsruhe described the progress that is being made in this respect. Topics of particular current interest include a careful treatment of multiple parton interactions and the implementation of next-to-leading-order (NLO) QCD matrix elements in Monte Carlo programs.

At present, lattice calculations still offer the most reliable framework for studies of QCD beyond the weak coupling limit. Among other issues, the workshop addressed the calculation of low-energy parameters such as hadron masses and decay constants. In this context, Federico Farchioni of Münster noted that the limit of small quark masses calls for careful attention, and Philipp Hägler of Technische Universität, München discussed developments in calculating hadron structure from the lattice. Another important direction concerns the QCD phase structure and, in particular, accurate estimates of the phase-transition temperature,  $T_c$ , as Akira Ukawa of Tsukuba explained. Lattice gauge theories also allow the investigation of connections with string theory. Michael Teper of Oxford showed how once the dependence of gauge theory on the number of colours,  $N_c$ , is sufficiently well controlled, it may be possible to determine the energy spectrum of closed strings in the limit of large 't Hooft coupling.

### QCD perturbation theory

NLO and next-to-NLO calculations in QCD perturbation theory are needed to derive precise expressions for cross-sections – they are crucial in describing experimental data at the existing colliders, and indispensable input for the discrimination of new physics from mere QCD background at the LHC. The necessary computations require a detailed understanding of perturbative QCD, as Werner Vogelsang from Brookhaven National Laboratory discussed. For example, the theoretical foundation of  $k_t$  factorization and of unintegrated parton densities, along with their use in hadron–hadron collisions, is attracting much attention. For higher-order QCD calculations, Alexander Mitov of DESY, Zeuthen, described how advanced algorithms are being developed and applied.

Higher-order computations in QCD are becoming one of the most prominent examples of an extremely profitable bridge between gauge and string theories. Multiparton final states at the LHC have sparked interest in perturbative gauge theory computations of scattering amplitudes that involve a large number of incoming and/or outgoing partons. At the same time there is an urgent need for higher-loop results, which, in view of the rapidly growing number of Feynman diagrams, seem to be out of reach for more conventional approaches. Recent investigations in this direction have unravelled new structures, such as in the perturbative expansion of multigluon amplitudes.

In a few special cases, such as four-gluon amplitudes in  $N = 4$

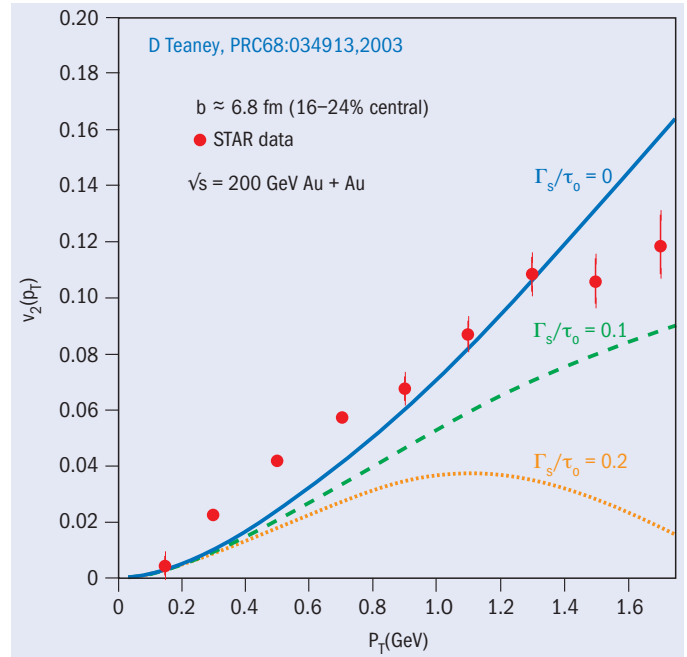

Elliptic flow,  $v_2$ , as a function of transverse momenta in a heavy-ion collision. The AdS/CFT calculation of the viscosity leads to  $\Gamma_s/\tau_0 \sim 0.11$ .

supersymmetric Yang–Mills theory, these investigations have led to highly non-trivial conjectures for all loop expressions. This was the topic of talks by David Dunbar of Swansea and Lance Dixon of Stanford. According to the AdS/CFT duality, the strong coupling behaviour of these amplitudes should be calculable within string theory. Indeed, Maldacena described how the relevant string-theory computation of four-gluon amplitudes has been performed, yielding results that agree with the gauge theoretic prediction. On the gauge theory side, a conjecture for a larger number of gluons has also been formulated. Maldacena noted that this is currently contested both by string theoretic arguments and more refined gauge theory calculations.

The expressions for four-gluon amplitudes contain a certain universal function, the so-called cusp anomalous dimension, which can again be computed at weak (gauge theory) and strong (supergravity) coupling. Gleb Arutyunov of Utrecht showed how this particular quantity is also being investigated using modern techniques of integrable systems. Remarkably, as Niklas Beisert of the Albert Einstein Institute in Golm explained, a formula for the cusp anomalous dimension in  $N = 4$  super-Yang–Mills theory has recently been proposed that interpolates correctly between the known weak and strong coupling expansions. In addition, Vladimir Braun of Regensburg and Lev Lipatov of Hamburg and St Petersburg described how integrability features in the high-energy regime of QCD, both in the short distance and the small- $x$  limit. The integrable structures have immediate applications to data analysis. Yuri Kovchegov of Ohio also pointed out that low- $x$  physics in QCD, with all the complexities appearing in the NLO corrections, might possess close connections with the supersymmetric relatives of QCD. The higher order generalization of the Balitsky–Fadin–Kuraev–Lipatov pomeron, which is expected to correspond to the graviton, is of particular interest. In this way, studies of the high-energy regime seem to carry the seeds for new relations to string theory.

Another close contact between string theory and QCD appears at temperatures near and above the QCD phase transition. Heavy-ion experiments that probe this kinematic region are currently taking place at RHIC and will soon be carried out at the LHC. CERN's Urs Wiedemann introduced the topic, and John Harris of Yale presented results and discussed their interpretation. The analysis of RHIC data requires somewhat unusual theoretical concepts, including, for example, QCD hydrodynamics. As in any other system of fluid mechanics, viscosity is an important parameter used to characterize quark-gluon plasmas, but its measured value cannot be explained through perturbative QCD. This suggests that the quark-gluon plasma at RHIC is strongly coupled, so string theory should be able to predict properties such as the plasma's viscosity through the AdS/CFT correspondence. David Mateos of Santa Barbara and Hong Liu of Boston showed that the string theoretic computation of viscosity and other quantities is indeed possible, based on investigations of gravity in a thermal black-hole background. It leads to values that are intriguingly close to experimental data.

String theory is often perceived as an abstract theoretical framework, far away from the physics of the real world and experimental verification. When considered as a theory of strongly coupled gauge physics, however, it is beginning to slip into a new role – one that offers novel views of qualitative features of gauge theory and, in some cases, even quantitative predictions. The QCD community, on the other hand, is beginning to realize that its own tremendous efforts may profit from the novel alliance with string theory. The par-

ticipants of the 2007 DESY Theory workshop witnessed this recent shift, through lively discussions and numerous excellent talks that successfully bridged the two communities.

#### Further reading

Slides of most talks can be found at <https://indico.desy.de/conferenceDisplay.py?confId=429>.

#### Résumé

*CDQ: la théorie des cordes rencontre la physique des collisionneurs*

*Maîtriser les complexités des interactions fortes sera fondamental pour la recherche d'une nouvelle physique au LHC. De nombreux physiciens cherchent donc à mieux comprendre la chromodynamique quantique (CDQ), la théorie des interactions fortes. On croyait la théorie des cordes incapable de prédire correctement le comportement de ces interactions à haute énergie, jusqu'à ce que Juan Maldacena ouvre la voie à une équivalence, ou «dualité», entre la théorie de jauge et la théorie des cordes. Avec cette dualité pour thème central, l'atelier DESY 2007 a rassemblé divers orateurs éminents, dont Maldacena, pour qu'ils présentent et examinent les avancées récentes et les idées nouvelles dans ces deux domaines.*

**Jochen Bartels**, Hamburg University, and **Volker Schomerus**, DESY.

## EPICS Oscilloscopes for Particle Accelerators



### EPICS Integration

- Embedded EPICS IOC
- PVs enable complete control via EPICS

### Compact Size

- Highest channel density performance scope on the market
- Rack mountable, 1U height, half-rack width

### Performance Oscilloscope Features

- 4 GS/s, 1 GHz bandwidth
- On-board math & waveform parameter calculations



Learn More at:  
[www.ztecinstruments.com/cc](http://www.ztecinstruments.com/cc)

# Control systems for big physics reach maturity

The 20th anniversary of ICALEPCS, the major biennial conference on control systems for accelerators and other large physics projects, reveals how the field is reaching maturity.

Control systems are a huge feature of the operation of particle accelerators and other large-scale physics projects. They allow completely integrated operation, including the continuous monitoring of sub-systems; display of statuses and alarms to operators; preparation and automation of scheduled operations; archiving data; and making all of the experimental data available to operators and system experts. The latest news from projects around the world formed the main focus of the 11th International Conference on Accelerator and Large Experimental Physics Control Systems (ICALEPCS), which took place on 13–19 October in Knoxville, Tennessee. More than 360 people from 22 countries attended the meeting hosted by the Oak Ridge National Laboratory (ORNL) and the Thomas Jefferson National Accelerator Facility at the Knoxville Conference Center. The 260 presentations, including 71 talks, confirmed the use of established technologies and reviewed their consolidation. Excellent poster sessions also provided plenty of opportunity for discussions with the authors during the coffee breaks.

The weekend prior to the conference saw three related meetings. Almost 50 people attended the Control System Cyber-Security workshop, where eight major laboratories presented and discussed current implementations and future prospects for securing control systems. All have acknowledged the risk and all follow a “defence-in-depth” approach, focusing on network protection and segregation, authorization and authentication, centralized PC installation schemes and collaboration between information-technology and controls experts.

## Approaches to control systems

In parallel, 200 people attended meetings of the collaborations developing the open-source toolkits EPICS and TANGO. The EPICS collaboration in particular has grown since previous ICALEPCS meetings. The contributions presented at the conference showed that these two toolkits are the most widely used and are the predominant choice for many facilities. For example, EPICS has recently been selected for use at the Spallation Neutron Source (SNS) at ORNL, while the control system of the ALBA light source in Spain will be based on TANGO.

Alternative solutions employ commercial supervisory control and data acquisition (SCADA) products for control systems. This is the case, for example, at CERN, the Laser Mégajoule project and the SOLEIL synchrotron. At CERN, the cryogenics system for the



*The conference included a tour of the Spallation Neutron Source, with its impressive klystrons. (Courtesy Pamela J Kite ORNL/NScD/RAD.)*

LHC and the LHC experiments, among others, make extensive use of commercial SCADA systems. The combination of their use with appropriate software frameworks developed in common has largely facilitated the design and construction of these control systems. They are currently being scaled up to their final operational size – a task that has gone smoothly so far (p20 and p24).

Independent of the approach adopted, the controls community has focused strongly on the software-development process, taking an increasing interest in risk reduction, improved productivity and quality assurance, as well as outsourcing. The conference learned of many



efforts for standardization and best practice, from the management of requirements to development, implementation and testing. Speakers from CERN, for example, explained the benefits of the adoption of the Agile design and programming methodology in the context of control-system development.

The ITER tokamak project in Cadarache, France, has taken an approach that uses a unified design to deal with the static and dynamic behaviour of subsystems. The operation of ITER requires the orchestration of up to 120 control systems, including all technical and plasma diagnostic systems. ITER will outsource a large fraction of these control systems, which will be procured "in kind" from the participating teams. Outsourcing also played a major role in the Australian Synchrotron and it involved co-operation between research institutions and industrial companies to enhance and optimize the functionality of their control-system products. Such collaboration needs the definition of strict acceptance criteria and deadlines, but it also allows outsourcing of the risk. The Mégajoule project tested its subcontracting process within a small "vertical slice", before adapting all of the outsourcing and the integration process to the full-scale system. The Atacama Large Millimetric and Submillimetric Array has provided further lessons about the successful organization of a distributed team and integration of different objects. The project enforced a common software framework on all participating teams, and the integration process focused on functionality rather than on the subsystems.

In addition to the software frameworks for control systems, there

are many plug-ins, tools and utilities under development, using, in particular, the Java language. For example, EPICS employs Java at all levels from the front-end Java input/output (I/O) controllers to the supervision layer. Java is now a top candidate for new developments, owing mostly to its productivity and portability, not only for graphical user interfaces (GUIs) and utilities but also for applications that are calculation intensive. The accelerator domain has integrated more advanced Java-related techniques successfully. SLAC, for example, has benefited from the open-source Eclipse technologies, and the Java-based open-source Spring is being deployed in the LHC accelerator control systems at CERN (p20). However, somewhat contrarily to these common efforts, individual projects have also developed a variety of new electronic logbooks and custom GUI builders.

The flexibility and portability of Java are becoming increasingly combined with the extensible markup language XML. With interoperability in mind, the growing (and correct) usage of XML and associated technologies provides a good basis for openness, data exchange and automation, rather than simply for configuration.

An example of this openness is the adoption of industrial solutions for data management. Modern control systems have seen a rapid growth in data to be archived, together with rising expectations for performance and scalability. File-based or dedicated solutions for data management are reaching their limits, so these techniques are now being replaced by high-performance databases, such as ▷

# X-Ray Detector

XR-100CR at **149 eV FWHM** Resolution

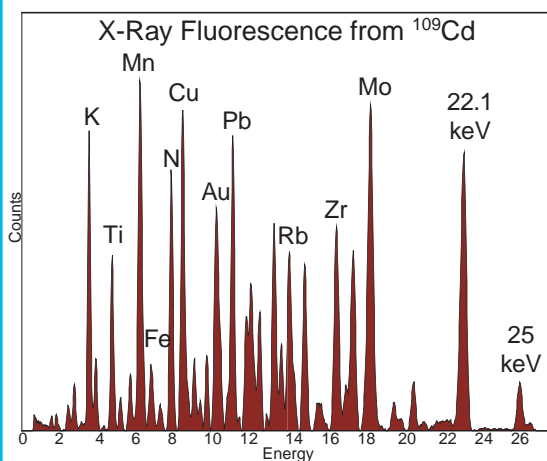

**No Liquid Nitrogen**

**Solid State Design**

**Easy to Use**

**Low Cost**

### APPLICATIONS

- Nuclear Physics
- Synchrotron Radiation
- High Energy Physics
- Neutron Experiments
- Astrophysics
- Research & Teaching
- Nuclear Medicine
- X-Ray Fluorescence

## Complete X-Ray Spectrometer

INCLUDES

- 1 X-Ray Detector and Pre-amplifier
- 2 Digital Pulse Processor and MCA
- 3 Power Supply



7 x 10 x 2.5 cm (2.7 x 3.9 x 1 in)

The X-123 is a complete X-Ray Detector System in one small box that fits in your hand.



XR100CR X-Ray Detector with PX4 Digital Pulse Processor, Power Supply, Shaping Amplifier & MCA



XR100CR fitted for vacuum applications

Visit Us Now [www.amptek.com](http://www.amptek.com)

### Features of the X-123:

- Simple to Operate
- Low Power (1.2 Watts)
- Small Size
- USB and RS232 Communication
- Accommodates all Amptek Detectors

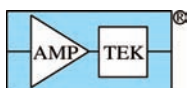

**AMPTEK Inc.** 14 DeAngelo Drive, Bedford, MA 01730-2204 USA  
 Tel: +1 (781) 275-2242 Fax: +1 (781) 275-3470  
 E-mail: [sales@amptek.com](mailto:sales@amptek.com) [www.amptek.com](http://www.amptek.com)

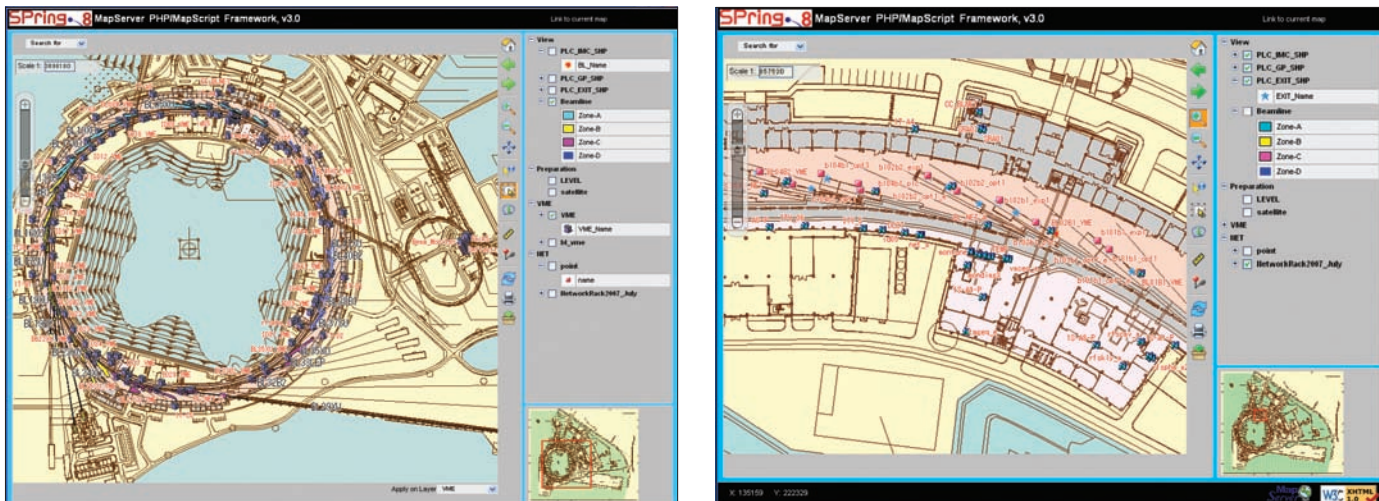

Fig.1. Accelerator management at SPring-8 in Japan uses a geographical information system. (Courtesy Akihiro Yamashita/SPring-8.)

Oracle and PostgreSQL. These databases not only record the parameters of control systems but also are used for administration, documentation management and equipment management. In addition to these well established technologies, some users have chosen ingenious approaches. For example, SPring-8 in Japan has a geographic information system integrated into its accelerator management (figure 1). The Google Maps-like system allows localizing, visualizing and monitoring of equipment in real time, and it has opened up interesting perspectives for the control systems community.

**Hardware becomes soft**

On the hardware side, VME equipment shows an increased use of embedded controllers, such as digital signal processors and field-programmable gate arrays. Their flexibility brings the controls software directly onto the front end, for example, as cross-compiled EPICS I/O controllers. The development of radiation hard front-ends, for example, for the Compact Linear Collider study and the LHC at CERN, have presented other challenges. Timing systems have also had to face new challenges: the LHC requires independent and asynchronous timing cycles of arbitrary duration; timing distributions, for the accelerators at SOLEIL or the Los Alamos Neutron Science Center, for example, are based on common networks with broadcasting clocks and event-driven data; and modern free-electron lasers (FELs), such as at SPring-8, depend on timing accuracies of femtoseconds to achieve stable laser beams.

FELs and light sources were the main focus of several status reports at the conference. The X-ray FEL project at SPring-8 has implemented its control system in MADOCA, a framework that follows a three-tier control model. The layers consist of an interface layer based on DeviceNet programmable logic controllers and VME crates; communication middleware based on remote procedure calls; and Linux consoles for the GUIs. The control system for the Free-electron Laser in Hamburg (FLASH) at DESY provides bunch-synchronized data recording using a novel integration of a fast DAQ system. The FLASH collaboration carried out an evaluation of the front-end crates used in the telecoms industry, which suggested that they had more reliable operation and integrated management compared with VME crates. The collaboration for the ALICE experiment at the LHC reported on progress with its control system, which is currently being installed,

commissioned and prepared for operation, due to start later this year. Other status reports came from the Facility for Antiproton and Ion Research at GSI and the Diamond Light Source in the UK.

The conference concluded with presentations about the new developments and future steps in the evolution of some of the major controls frameworks. These underlined that the ICALEPCS conference not only confirmed the use of established technologies and designs, in particular EPICS and TANGO, but also showed the success of commercial SCADA solutions. Control systems have become highly developed and the conference reviewed consolidation efforts and extensions thoroughly. The social programme included a dinner with bluegrass music and an excellent tour of the SNS, the world’s most intense pulsed accelerator-based neutron source, which rounded off the meeting nicely. Now the controls community awaits the 12th ICALEPCS conference, to be held in Kobe, Japan, in autumn 2009.

**Further reading**

For most of the material presented at the ICALEPCS 2007 and the links to the affiliated meetings, see <http://neutrons.ornl.gov/conf/icalepcs07>.

**Résumé**

*Les systèmes de contrôle pour la physique arrivent à maturité*

*Les systèmes de contrôle jouent un rôle essentiel dans l'exploitation des accélérateurs de particules et d'autres grands projets de physique. La 11<sup>e</sup> Conférence internationale sur les systèmes de commande des accélérateurs et des grandes expériences de physique (ICALEPCS), qui s'est tenue en octobre à Knoxville (Tennessee), a fait le point sur les projets actuels. Pour son 20<sup>e</sup> anniversaire, cette importante conférence biennale a laissé apparaître un domaine proche de la maturité. Les exposés ont confirmé l'exploitation de technologies éprouvées et passé en revue leur perfectionnement, dans le cadre de projets tels que le grand collisionneur de hadrons (LHC), au CERN, le Laser Mégajoule et ITER.*

**Mathias Dutour, Stefan Lüders, Jerónimo Ortolá Vidal, Fernando Varela Rodríguez, CERN.**



# PHOTONIS

## INDUSTRY & SCIENCE

Your partner for new detection solutions

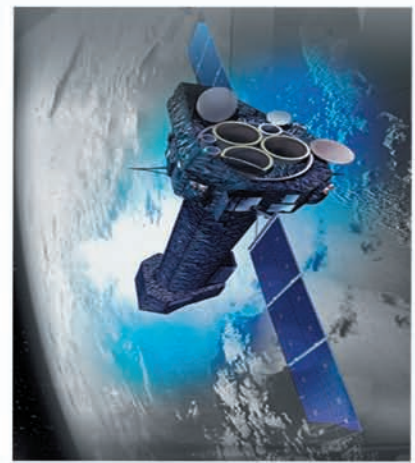

### Electron Multiplier

CHANNELTRON®

From the World leader in Electron Multipliers, Advanced Performance & MCP/TOF Detectors

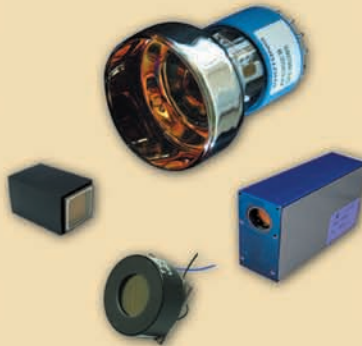

### Light Sensor

CLARITY

Multi-Pixel Photomultipliers, High Sensitivity Photon Counters, Low Light Image Intensifiers & Hybrid PhotoDetectors (HPD)



### Extreme Detector

Long-Life™ MCP

High Neutron & Gamma Flux, Ultra-Fast Streak Tubes, MicroChannel Plates Detectors for X-Ray Optics, UV & Space

PHOTONIS USA, Inc. Sturbridge Business Park, P.O. Box 1159 Sturbridge, MA 01566-1159. USA T: +1-800-648-1800 or +1-508-347-4000  
 PHOTONIS France SAS Avenue Roger Roncier - BP520 19106 BRIVE Cedex. France T: +33 (0)555 86 37 00

For more information, please visit [www.photonis.com](http://www.photonis.com) or email [sales@photonis.com](mailto:sales@photonis.com)

# Under control: keeping t

Each stage of the LHC project has presented its own challenges, including the final operational phase

The scale and complexity of the Large Hadron Collider (LHC) under construction at CERN are unprecedented in the field of particle accelerators. It has the largest number of components and the widest diversity of systems of any accelerator in the world. As many as 500 objects around the 27 km ring, from passive valves to complex experimental detectors, could in principle move into the beam path in either the LHC ring or the transfer lines. Operation of the machine will be extremely complicated for a number of reasons, including critical technical subsystems, a large parameter space, real-time feedback loops and the need for online magnetic and beam measurements. In addition, the LHC is the first superconducting accelerator built at CERN and will use four large-scale cryoplants with 1.8 K refrigeration capability (*CERN Courier* May 2004, p15).

The complexity means that repairs of any damaged equipment will take a long time. For example, it will take about 30 days to change a superconducting magnet. Then there is the question of damage if systems go wrong. The energy stored in the beams and magnets is more than twice the levels of other machines. That accumulated in the beam could, for example, melt 500 kg of copper. All of this means that the LHC machine must be protected at all costs. If an incident occurs during operation, it is critical that it is possible to determine what has happened and trace the cause. Moreover, operation should not resume if the machine is not back in a good working state.

The accelerator controls group at CERN has spent the past four years developing a new software and hardware control system architecture based on the many years of experience in controlling the particle injector chain at CERN. The resulting LHC controls infrastructure is based on a classic three-tier architecture: a basic resource tier that gathers all of the controls equipment located close to the accelerators; a middle tier of servers; and a top tier that interfaces with the operators (figure 1).

## Complex architecture

The LHC Software Application (LSA) system covers all of the most important aspects of accelerator controls: optics (twiss, machine layout), parameter space, settings generation and management (generation of functions based on optics, functions and scalar values for all parameters), trim (coherent modifications of settings, translation from physics to hardware parameters), operational exploitation, hardware exploitation (equipment control, measurements) and beam-based measurements. The software architecture is based on three main principles (figure 2). It is modular (each module has high cohesion, providing a clear application program interface to its functionality), layered (with three isolated logical layers – database and hardware access layer, business layer, user applications) and distributed (when deployed in the three-tier configuration). It provides homogenous application soft-

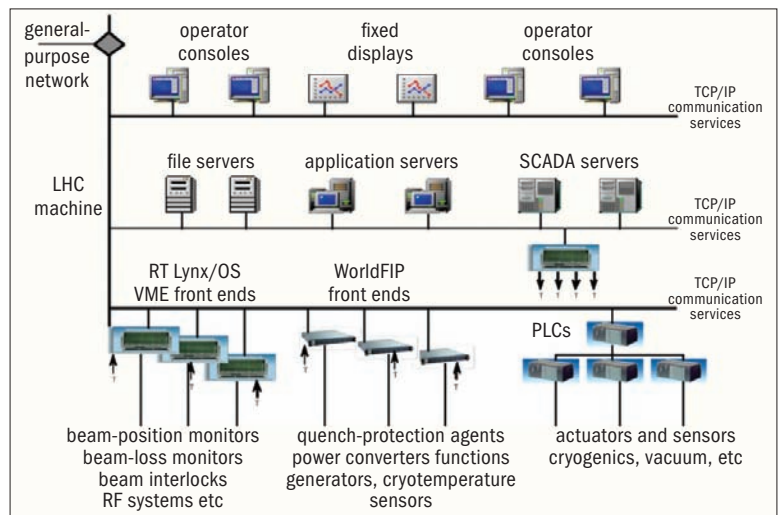

Fig. 1. The complex LHC controls infrastructure network comprises three tiers.

ware to operate the SPS accelerator, its transfer lines and the LHC, and it has already been used successfully in 2005 and 2006 to operate the Low Energy Ion Ring (LEIR) accelerator, the SPS and LHC transfer lines.

# the LHC beams on track

phase, where the controls infrastructure has to ensure the correct operation of this complex machine.

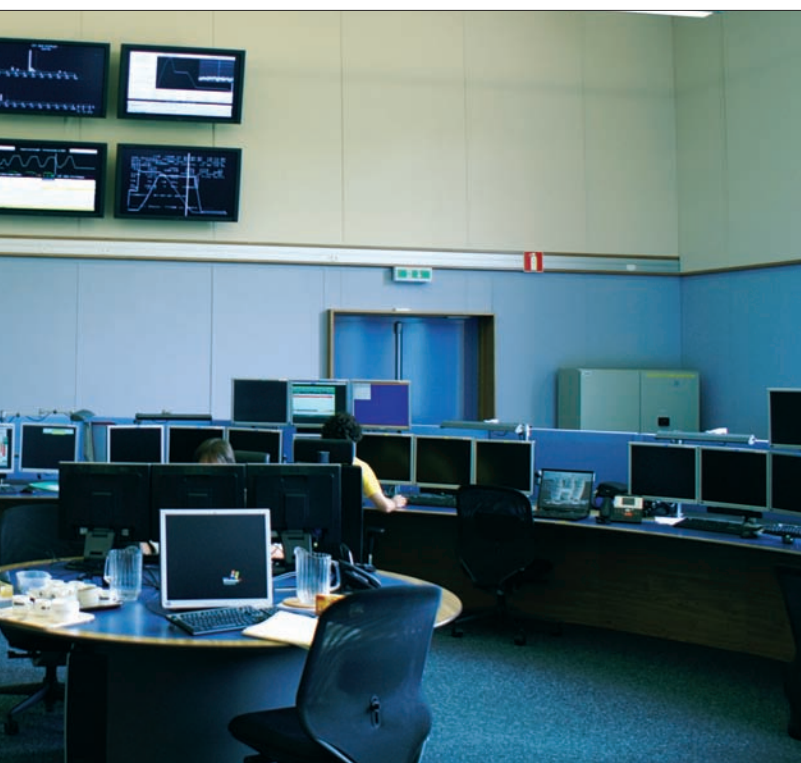

Fig. 3. The CERN control centre during the first days of use in 2006 (top); and today (left). Above: A close-up of a typical LHC operation console.

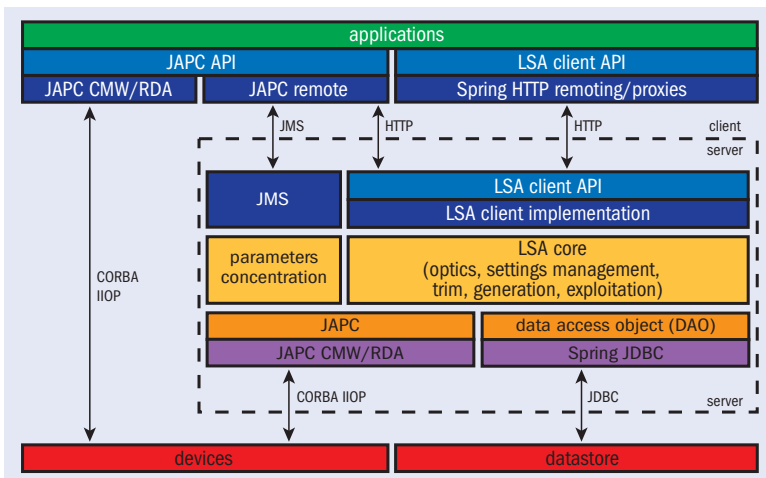

Fig. 2. The architecture of the LHC software application (LSA) is designed to be modular, layered and distributed and provides operators with real-time data.

The front-end hardware of the resource tier consists of 250 VME-bus64x sub-racks and 120 industrial PCs distributed in the surface buildings around the 27 km ring of the LHC. The mission of these systems is to perform direct real-time measurements and data

acquisition close to the machine, and to deliver this information to the application software running in the upper levels of the control system. These embedded systems use home-made hardware and commercial off-the-shelf technology modules, and they serve as managers for various types of fieldbus such as WorldFIP, a deterministic bus used for the real-time control of the LHC power converters and the quench-protection system. All front ends in the LHC have a built-in timing receiver that guarantees synchronization to within 1  $\mu$ s. This is required for time tagging of post-mortem data. The tier also covers programmable logic controllers, which drive various kinds of industrial actuator and sensor for systems, such as the LHC cryogenics systems and the LHC vacuum system.

The middle tier of the LHC controls system is mostly located in the Central Computer Room, close to the CERN Control Centre (CCC) (CERN Courier May 2006, p15.). This tier consists of various servers: application servers, which host the software required to operate the LHC beams and run the supervisory control and data acquisition (SCADA) systems; data servers that contain the LHC layout and the controls configuration, as well as all of the machine settings needed to operate the machine or to diagnose machine behaviours; and file servers containing the operational applications. More than 100 servers provide all of these services. The middle tier also ▷

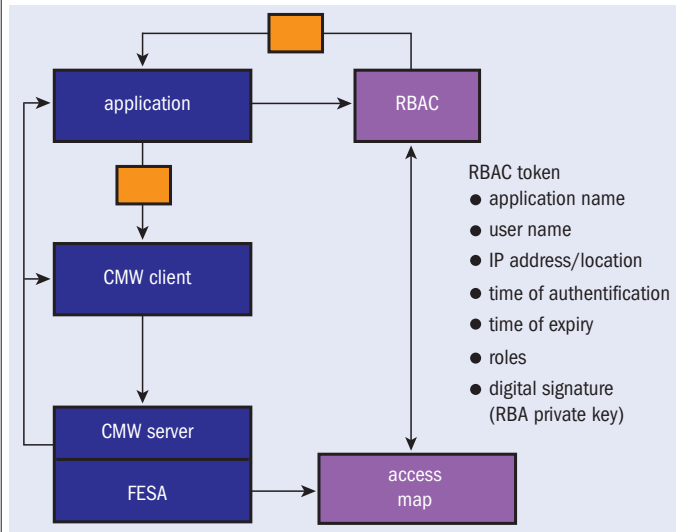

Fig. 4. Tokens and access maps for the role-based access control (RBAC).

includes the central timing that provides the information for cycling the whole complex of machines involved in the production of the LHC beam, from the linacs onwards.

At the top level – the presentation tier – consoles in the CCC run GUIs that will allow machine operators to control and optimize the LHC beams and supervise the state of key systems. Dedicated displays provide real-time summaries of key machine parameters. The CCC is divided into four “islands”, each devoted to a specific task: CERN’s PS complex; the SPS; technical services; and the LHC. Each island is made of five operational consoles and a typical LHC console is composed of five computers (figure 3, p21). These are PCs running interactive applications, fixed displays and video displays, and they include a dedicated PC connected only to the public network. This can be used for general office activities such as e-mail and web browsing, leaving the LHC control system isolated from exterior networks.

### Failsafe mechanisms

In building the infrastructure for the LHC controls, the controls groups developed a number of technical solutions to the many challenges facing them. Security was of paramount concern: the LHC control system must be protected, not only from external hackers, but also from inadvertent errors by operators and failures in the system. The Computing and Network Infrastructure for Controls is a CERN-wide working group set up in 2004 to define a security policy for all of CERN, including networking aspects, operating systems configuration (Windows and Linux), services and support (Lüders 2007). One of the group’s major outcomes is the formal separation of the general-purpose network and the technical network, where connection to the latter requires the appropriate authorization.

Another solution has been to deploy, in close collaboration with Fermilab, “role-based” access (RBAC) to equipment in the communication infrastructure. The main motivation to have RBAC in a control system is to prevent unauthorized access and provide an inexpensive way to protect the accelerator. A user is prevented from entering the wrong settings – or from even logging into the application at all. RBAC works by giving people roles and assigning permissions to those roles to make settings. An RBAC token – containing information about the user, the application, the location, the role

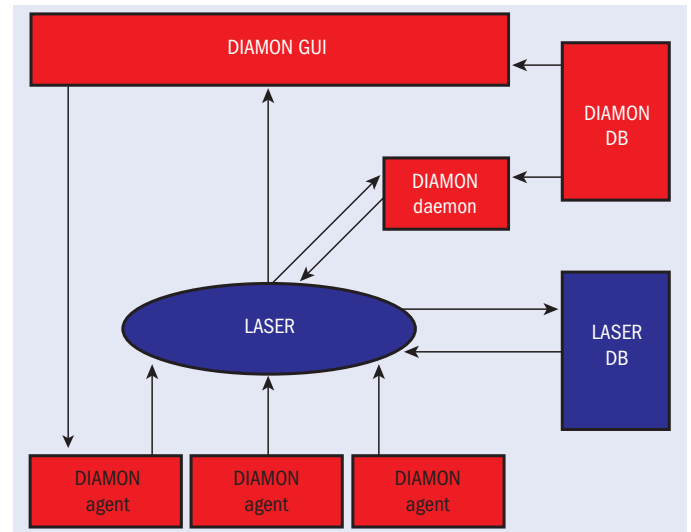

Fig. 5. Architecture for the diagnostics and monitoring project, DIAMON.

and so on – is obtained during the authentication phase (figure 4). This is then attached to any subsequent access to equipment and is used to grant or deny the action. Depending on the action made, who is making the call and from where, and when it is executed, access will be either granted or denied. This allows for filtering, control and traceability of modifications to the equipment.

An alarm service for the operation of all of the CERN accelerator chain and technical infrastructure exists in the form of the LHC Alarm Service (LASER). This is used operationally for the transfer lines, the SPS, the CERN Neutrinos to Gran Sasso (CNGS) project, the experiments and the LHC, and it has recently been adapted for the PS Complex (Sigerud *et al.* 2005). LASER provides the collection, analysis, distribution, definition and archiving of information about abnormal situations – fault states – either for dedicated alarm consoles, running mainly in the control rooms, or for specialized applications.

LASER does not actually detect the fault states. This is done by user surveillance programs, which run either on distributed front-end computers or on central servers. The service processes about 180 000 alarm events each day and currently has more than 120 000 definitions. It is relatively simple for equipment specialists to define and send alarms, so one challenge has been to keep the number of events and definitions to a practical limit for human operations, according to recommended best practice.

The controls infrastructure of the LHC and its whole injector chain spans large distances and is based on a diversity of equipment, all of which needs to be constantly monitored. When a problem is detected, the CCC is notified and an appropriate repair has to be proposed. The purpose of the diagnostics and monitoring (DIAMON) project is to provide the operators and equipment groups with tools to monitor the accelerator and beam controls infrastructure with easy-to-use first-line diagnostics, as well as to solve problems or help to decide on responsibilities for the first line of intervention.

The scope of DIAMON covers some 3000 “agents”. These are pieces of code, each of which monitors a part of the infrastructure, from the fieldbuses and frontends to the hardware of the control-room consoles. It uses LASER and works in two main parts: the monitoring part constantly checks all items of the controls infrastructure and reports on problems; while the diagnostic part displays the overall status of

the controls infrastructure and proposes support for repairs.

The frontend of the controls system has its own dedicated real-time frontend software architecture (FESA). This framework offers a complete environment for equipment specialists to design, develop, deploy and test equipment software. Despite the diversity of devices – such as beam-loss monitors, power converters, kickers, cryogenic systems and pick-ups – FESA has successfully standardized a high-level language and an object-oriented framework for describing and developing portable equipment software, at least across CERN's accelerators. This reduces the time spent developing and maintaining equipment software and brings consistency across the equipment software deployed across all accelerators at CERN.

This article illustrates only some of the technical solutions that have been studied, developed and deployed in the controls infrastructure in the effort to cope with the stringent and demanding challenges of the LHC. This infrastructure has now been tested almost completely on machines and facilities that are already operational, from LEIR to the SPS and CNGS, and LHC hardware commissioning. The estimated collective effort amounts to some 300 person-years and a cost of SFr21 m. Part of the enormous human resource comes from international collaborations, the valuable contributions of which are hugely appreciated. Now the accelerator controls group is confident that they can meet the challenges of the LHC.

● This article is based on the author's presentation at ICALEPCS '07 (p16). Further information about the paper, which contains references to other presentations on the LHC controls, can be found at

<http://ics-web4.sns.ornl.gov/icalepcs07/MOAB01/MOAB01.PDF>.

#### Further reading

S Lüders 2007 *CERN Computing Newsletter* **42** no5.

K Sigerud, N Stapley and M Misiowiec "First Operational Experience with LASER" ICALEPCS 2005.

For papers related to the LHC controls infrastructure, presented at the ICALEPCS '07 conference, see [www.icalepcs.org](http://www.icalepcs.org).

#### Résumé

*Faisceaux du LHC: les systèmes de contrôle veillent au grain*

*Le Grand collisionneur de hadrons (LHC) comprend les plus nombreux composants et les plus divers systèmes qu'un accélérateur ait jamais possédés. Les groupes chargés du contrôle du LHC au CERN ont consacré les quatre dernières années à développer une nouvelle architecture logicielle et matérielle de système de contrôle, grâce à plusieurs années d'expérience du contrôle de la chaîne d'injection des particules au CERN. L'infrastructure de contrôle du LHC qu'ils ont conçue repose sur une architecture classique à trois niveaux: un premier niveau de ressources regroupant tous les équipements de contrôle situés à proximité des accélérateurs; un niveau intermédiaire de serveurs; et un niveau supérieur, qui assure l'interface avec les opérateurs.*

**Pierre Charrue**, on behalf of the AB Controls Group, CERN.

## RF Amplifiers

**QEI Corporation will design and manufacture to your RF Amplifier needs.** Our 35 years of experience allows us to work with you to complete your requirements on time and within budget. Whether you require solid state or tube, air or water cooling, CW or pulse, HF to UHF, we can meet your needs. To discuss your project, contact QEI at 800-334-9154 (USA), 1-856-728-2020 (International), or via e-mail at [qeisales@qei-rf.com](mailto:qeisales@qei-rf.com).



8KW, 200MHz, CW, Water Cooled, Solid State RF Amp

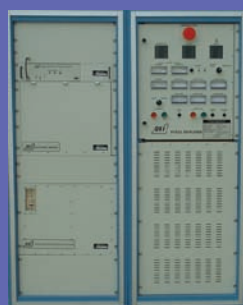

25KW, 18-32MHz, CW, Water Cooled, RF Amplifier



QEI Corporation • One Airport Dr • PO Box 805 • Williamstown, NJ 08094 USA • 800-334-9154 (USA)  
1-856-728-2020 (International) • [qeisales@qei-rf.com](mailto:qeisales@qei-rf.com) (e-mail) • <http://www.qei-broadcast.com>

# JANIS

## CRYOGENICS FROM JANIS



- 10 mK to 800 K
- Cryocoolers
- LHe/LN<sub>2</sub> Cryostats
- Magnet Systems
- Dilution Refrigerator Systems
- Micromanipulated Probe Stations

**Janis Research Company**

2 Jewel Drive Wilmington, MA 01887 USA  
TEL +1 978 657-8750 FAX +1 978 658-0349 [sales@janis.com](mailto:sales@janis.com)

Visit our website at [www.janis.com](http://www.janis.com).

# Detector controls for LHC experiments

CERN and the collaborations have worked together on a new approach to detector-control systems for the LHC experiments, leading to a model that could be applied in future particle-physics projects. **Wayne Salter** explains.

Traditionally at CERN, teams on each experiment, and in some cases each subdetector, have independently developed a detector-control system (DCS) – sometimes known as “slow controls”. This was still the case for the experiments at LEP. However, several factors – the number and geographical distribution of development teams, the size and complexity of the systems, limited resources, the long lifetime (20 years) and the perceived similarity between the required systems – led to a change in philosophy. CERN and the experiments’ management jointly decided to develop, as much as possible, a common DCS for the LHC experiments. This led to the setting up in 1997 of the Joint Controls Project (JCOP) as a collaboration between the controls teams on the LHC experiments and the support groups in CERN’s information technology and physics departments.

The early emphasis in JCOP was on the difficult task of acquiring an understanding of the needs of the experiments and agreeing on common developments and activities. This was a period where disagreements were most prevalent. However, with time the collaboration improved and so did progress. Part of this early effort was to develop a common overall architecture that would become the basis of many of the later activities.

## The role of JCOP

In parallel, the JCOP team undertook evaluations to assess the suitability of a number of technologies, primarily commercial ones, such as OLE for Process Control (OPC), the field buses CANBus and ProfiBus, commercial programmable logic controllers (PLCs), as well as supervisory control and data acquisition (SCADA) products. The evaluation of SCADA products eventually led to the selection of the Prozessvisualisierung und Steuerungs System (PVSS) tool as a major building block for the DCS for experiments (*CERN Courier* June 2005 p20). The CERN Controls Board subse-

quently selected PVSS as the recommended SCADA system for CERN. In addition, and where suitable commercial solutions were not available, products developed at CERN were also evaluated. This led to JCOP’s adoption and support of CERN’s distributed information manager (DIM) middleware system and the SMI++ finite-state machine (FSM) toolkit. Furthermore, developments made in one experiment were also adopted by other experiments. The best example of this is the embedded local monitor board (ELMB) developed by ATLAS. This is a small, low-cost, high-density radiation-tolerant input/output card that is now used extensively in all LHC experiments, as well as in some others.

One major thrust has been the development of the so-called JCOP framework (FW) (figure 1). Based on specifications agreed with the experiments, this provides a customized layer on top of the technologies chosen, such as PVSS, SMI++ and DIM. It offers many ready-to-use components for the control and monitoring of standard devices in the experiments (e.g. CAEN high voltage, Wiener and CAEN low voltage, the ELMB and racks). The FW also extends the functionality of the underlying tools, such as the configuration database tool and installation tool.

These developments were not only the work of the CERN support groups but also depended on contributions from the experiments. In this way the development and maintenance was done once and used by many. This centralized development has not only significantly reduced the overall development effort but will also ease the long-term maintenance – an issue typically encountered by experiments in high-energy physics where short-term collaborators do much of the development work.

As figure 1 shows, the JCOP FW has been developed in layers based on a component model. In this way each layer builds on the facilities offered by the layer below, allowing subdetector groups to pick and choose between the components on offer, taking only those that they require. The figure also illustrates how the JCOP FW, although originally designed and implemented for the LHC experiments, can be used by other experiments and applications owing to the approach adopted. Some components in particular have been incorporated into the unified industrial control system (UNICOS) FW, developed within the CERN accelerator controls group (p20). The UNICOS FW, initially developed for the LHC cryogenics control system, is now used for many applications in the accelerator domain and as the basis for the gas-control systems (GCS) for the LHC experiments.



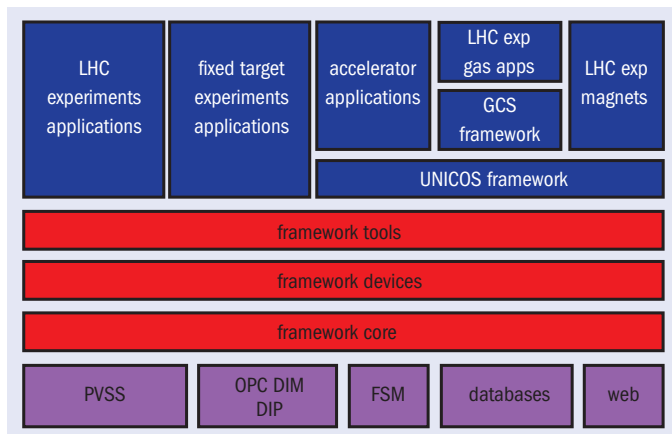

Fig. 1. The layered structure and use of the Joint Controls Project framework, indicating its basis on both commercial (e.g. PVSS) and CERN-developed products (e.g. the distributed information manager (DIM) and finite-state machine (FSM) toolkit.).

In addition to these development and support activities, JCOP provides an excellent forum for technical discussions and the sharing of experience across experiments. There are regular meetings, both at the managerial and the technical levels, to exchange information and discuss issues of concern for all experiments. A number of more formal workshops and reviews have also taken place involving experts from non-LHC experiments to ensure the relevance and quality of the products developed. Moreover, to maximize the efficiency and use of PVSS and the JCOP FW, JCOP offers tailor-made training courses. This is particularly important because the subdetector-development teams have a high turnover of staff for their controls applications. To date, several hundred people have attended these courses.

As experiments have not always tackled issues at the same time, this common approach has allowed them to benefit from the experience of the first experiment to address a particular problem. In addition, JCOP has conducted a number of test activities, which cover the testing of commonly used commercial applications, such as various OPC servers, as well as the scalability of many of the supported tools. Where the tests indicated problems, this provided feedback for the tool developers, including the commercial suppliers. This in turn resulted in significant improvements in the products.

### Building on the framework

Although JCOP provides the basic building blocks and plenty of support, there is still considerable work left for the subdetector teams around the world who build the final applications. This is a complex process because there are often several geographically distributed groups working on a single subdetector application, and all of the applications must eventually be brought together and integrated into a single homogeneous DCS. For this to be possible, the often small central experiment controls teams play a significant role (figure 2). They not only participate extensively in the activities of JCOP, but also have other important tasks to perform, including development of guidelines and recommendations for the subdetector developments, to ensure easy integration; customization and extension of the JCOP FW for the experiment's specific needs (e.g. specific hardware used in their experiment but not in the others); support and consultation for the subdetector teams;

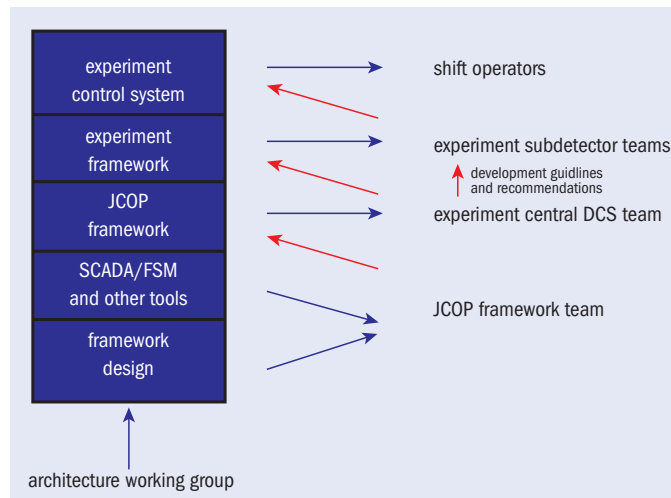

Fig. 2. The development approach for the DCS for the LHC experiments, which involves different groups of people at the different levels.

development of applications for the monitoring and control of the general experiment infrastructure e.g. for the control of racks and environmental monitoring.

As well as selecting, developing and supporting tools to ease the development of the DCSs, there have been two areas where complete applications have been developed. These are the detector safety systems (DSS) and the gas control systems (GCS). The DSS, which is based on redundant Siemens PLCs and PVSS, has been developed in a data-driven manner that allows all four LHC experiments to configure it to their individual needs. Although not yet fully configured, the DSS is now deployed in the four experiments and has been running successfully in some for more than a year.

The approach for the GCS goes one step further. It is also based on PLCs (Schneider Premium) and PVSS, but the PLC and PVSS code of the 23 GCSs is generated automatically using a model-based development technique. In simple terms, there is a generic GCS model that includes all possible modules and options, and each GCS application is defined by a particular combination of these modules and options. The final GCS application is created by selecting from a set of predefined components and configuring them appropriately using an application builder created for the purpose. All 23 GCSs have been generated in this way and are now deployed.

At the time of writing, the four LHC experiment collaborations were all heavily engaged in the commissioning of their detectors and control systems. To date, the integration of the various subdetector-control systems has proceeded relatively smoothly, owing to the homogeneous nature of the subdetector implementations. However, that is not to say that it has been problem free. Some issues of scaling and performance have emerged as the systems have increased in size, with more and more of the detectors being commissioned. However, thanks to the JCOP collaboration, it has been possible to address these issues in common for all experiments.

Despite some initial difficulties, the players involved see the approach described in this article, as well as the JCOP collaboration, as a success. The key here has been the building of confidence between the central team and its clients through the transparency of the procedures used to manage the project. All of the partners ▽

integrated

# ELECTROMAGNETIC SIMULATION SOFTWARE

Photomultiplier tube modeled in LORENTZ 6.2, a program for analyzing particle trajectories, electron and ion beam optics. LORENTZ's calculations include full secondary emissions, emittance, spot size and radius. Image courtesy of ADIT.

ES' easy-to-use field solver software gives you fast and accurate answers.

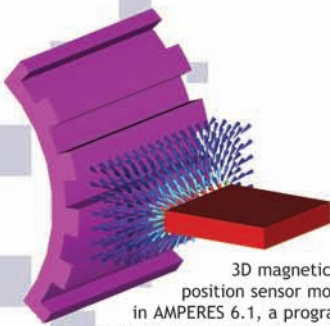

3D magnetic position sensor modeled in AMPERES 6.1, a program for analyzing magnetic components incorporating linear, non-linear and permanent magnet materials. AMPERES' calculations include force, torque, flux linkage and inductance.

Choose from a variety of programs to help you design products better and faster than your competitors.

**REQUEST YOUR FULL-VERSION SOFTWARE EVALUATION PACKAGE TODAY!**

Call 204.632.5636,  
email [info@integratedsoft.com](mailto:info@integratedsoft.com),  
or visit [www.integratedsoft.com](http://www.integratedsoft.com)



## LHC FOCUS

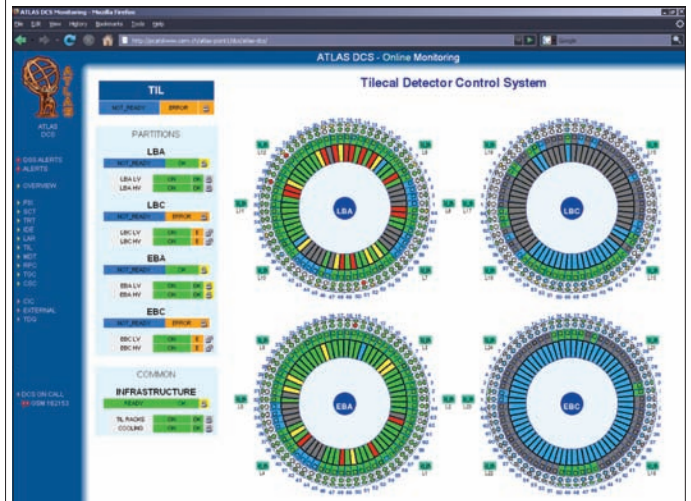

Detector control display for the Tile Calorimeter in the ATLAS experiment.

need to understand what is being done, what resources are available and that the milestones will be adhered to. The benefits of this collaborative approach include less overall effort, through the avoidance of duplicate development; each central DCS and sub-detector team can concentrate on their own specific issues; easier integration between developments; sharing of knowledge and experience between the various teams; and greater commonality between the experiment systems enables the provision of central support. In addition, it is easier to guarantee long-term maintenance with CERN-based central support. Compared with previous projects, JCOP has led to a great deal of commonality between the LHC experiments' DCSs, and it seems likely that with more centralized resources even more could have been achieved in common.

Could the JCOP approach be applied more widely to other experiment systems? If the project has strong management, then I believe so. Indeed, the control system based on this approach for the LHCb experiment is not limited to the DCS but also covers the complete experiment-control system, which includes the trigger, data-acquisition and readout systems as well as the overall run control. Only time will tell if this approach can, and will, be applied more extensively in future projects.

### Résumé

*Le contrôle de détecteur dans une perspective conjointe*

*Traditionnellement, au CERN, chaque collaboration développait son propre système de contrôle de détecteur. Cependant, certains facteurs, tels que le nombre et la répartition géographique des équipes de développement, les ressources limitées et la taille et la complexité des systèmes, ont conduit à changer de philosophie. Ainsi, pour les expériences du LHC, le CERN et les collaborations travaillent ensemble aux systèmes de contrôle des détecteurs, selon une approche conjointe. Malgré quelques difficultés au départ, cette collaboration s'avère un succès. Parmi les avantages: moins de travail au final grâce à l'élimination des développements redondants, échange d'expériences et de connaissances et mise en place d'un support centralisé.*

**Wayne Salter, CERN.**

# Trieste workshop puts a RICH variety on show

The 6th international workshop on ring imaging Cherenkov counters confirmed the vitality of this detector technique, with its many new developments. **Silvia Dalla Torre** reports.

Ring imaging Cherenkov (RICH) counters provide a unique tool to identify charged particles by measuring their velocity, even when it differs from the velocity of light by only one part in 10 million. The devices detect the visible and UV photons emitted through the Cherenkov effect, measuring the angle of the Cherenkov radiation with an imaging technique, and hence the velocity. This method offers the possibility of measuring particle velocity in domains where others fail, opening the way to particle identification over a wide range of particle momenta. In the current era of high-resolution and high-precision experiments, the domain of applications is becoming even larger, and more challenging requirements for the design of new detectors are arising.

The 6th International Workshop on Ring Imaging Cherenkov Counters, which took place in Trieste on 15–20 October 2007, covered all of this and more, with experts from around the world to analyse both the state of the art and novel perspectives in the field. Hosted by the Sezione di Trieste of INFN, this was the latest in a series of meetings that have become a reference point in the field of Cherenkov imaging detectors (*CERN Courier* May 2005 p33). The tradition continued at the Trieste meeting, attracting 120 participants – a quarter coming from outside Europe – with its scientific programme of invited and contributed talks and poster contributions. The workshop also recognized young researchers in the field with the RICH2007–NIM A Young Scientists' Award, offered by Elsevier for young scientists (under the age of 32) attending the workshop and contributing with a talk or a poster. Nine young people were eligible, and the RICH2007 International Scientific Advisory Committee, chaired by Eugenio Nappi of Bari, awarded the prize to Federica Sozzi, a PhD physics student from the University of Trieste.

## From RHIC to DIRC

The workshop provided an opportunity to confirm the central role that RICH detectors play in particle and nuclear physics, where they form key systems in current and future experiments in a variety of fields: light and heavy quark spectroscopy, K and B physics, nucleon structure, quark–gluon plasma, heavy-ion physics, hadronic matter and hypernuclei. This was evident in the comprehensive review by David Websdale of Imperial College London and in a number of contributions, several dedicated to RICH counters in experiments at CERN,



Junji Haba of KEK begins his review of photon detectors. (Courtesy INFN.)

such as the successful upgrade of RICH-1 in COMPASS, the high-momentum particle-identification detector for ALICE and the RICH detectors for LHCb (*CERN Courier* July/August 2007 p30). In experimental astroparticle physics, RICH detectors are indispensable in balloon and satellite-borne experiments studying the composition of cosmic rays. They also form the complete apparatus in telescopes to detect solar and cosmic neutrinos and in high-energy gamma-ray astronomy, as Eckhart Lorenz of the Max Planck Institute for Physics Munich and ETH Zurich emphasized in his exciting review.

The most innovative approaches in Cherenkov ring imaging techniques that were presented at the meeting centred on concepts derived from the detection of internally reflected Cherenkov light (DIRC) technique. Pioneered in the BaBar experiment at SLAC, this uses quartz as both a radiator and a light guide. Kenji Inami of Nagoya described the time-of-propagation approach, ▷

illustrating it with recent results from a test beam. In this technique the measurement of a space co-ordinate is replaced by the high-resolution measurement of a time co-ordinate, resulting in a much smaller photon-detector array. A further development of the DIRC concept is to use fast pixelated photon detectors, which provide high-resolution timing, in order to correct for chromatic dispersion of Cherenkov photons generated in the quartz radiator bars. The focusing-DIRC approach applies this technique and uses a focusing mirror to allow the dispersion of the measured Cherenkov angles generated by the thickness of the quartz bars to be reduced. Jochen Schwiening of SLAC showed how a focusing-DIRC prototype operated in a test beam has demonstrated for the first time the possibility of correcting the chromatic effect, thereby making possible a substantial gain in detector resolution.

The DIRC-derived detectors are largely based on the exceptional time resolution of a few tens of picoseconds that can be obtained with microchannel plate photomultipliers. The characteristics of these photon detectors open the way to other frontier applications, such as the compact time-of-flight detector that Jerry Va'vra of SLAC presented. In the field of vacuum-based photon detectors, which CERN's Thierry Gys reviewed, traditional photomultipliers can today be produced with a greatly increased quantum efficiency, with peak values more than 40%. Furthermore, hybrid photodetectors, which are vacuum-based detectors where the photoelectrons created are detected in silicon, have become a firm reality, thanks to mass production for the RICH detectors in LHCb.

### Innovative approaches

Solid-state and gaseous photon detectors were review topics broached by Junji Haba of KEK and Rachel Chechik of the Weizmann Institute, respectively. The first tests of Cherenkov ring imaging with silicon photomultipliers were reported by Samo Korpar of Ljubljana. In gaseous photon counters, despite the success of the first photon detectors with a solid-state photocathode – namely, multiwire proportional chambers equipped with a layer of caesium iodide as photoconverter – there are problems in exposing a photocathode to a gaseous atmosphere. The bombardment of the photocathode by ions flowing back from the amplification region results in performance limitations. Closed geometries, such as those achieved in multistage micropattern gaseous detectors, represent the new frontier, making possible drastic reductions of the ion backflow down to less than one part in a thousand. The new Cherenkov detector that forms the Hadron Blind Detector of the PHENIX experiment at RHIC at Brookhaven, which has been in operation for several months, is the first counter to follow this innovative approach.

The optimal performance of sophisticated detectors like RICH counters requires excellent technical and technological achievements in a variety of sectors, often achieved using innovative and challenging approaches. This was confirmed by the large number of new developments and ideas discussed at RICH2007. Groups in Novosibirsk and Japan have attained new goals in the production of aerogel, in particular in terms of improved transparency and the production of tiles with a variable refractive index. Optical components in Cherenkov imaging detectors are becoming increasingly important and the requirements now include mirrors, lenses and systems to control and monitor the alignment of huge optical arrangements. The new emphasis on high-resolution time measure-

ments requires extended electronic readout systems to preserve the detector time resolution, such as already in use for the multi-anode photomultiplier tubes of RICH-1 in COMPASS. Sophisticated detector-control systems guarantee optimal performance of the detectors in operation, as in LHCb experiment, for example.

Last but certainly not least, as Guy Wilkinson of Oxford explained, effective algorithms for image-pattern recognition and particle identification are key elements in optimizing the response of Cherenkov imaging counters. Even though the algorithms are applied to different arrangements, there are some common choices: Hough transformations convert the measured quantities into co-ordinates in a space more naturally related to the Cherenkov effect; and likelihood-based algorithms maximize the amount of information extracted from the data.

More exotic applications include the detection of Cherenkov radiation in the radio wavelength region for astroparticle research, as Amy Connolly of University College London discussed. The use of Cherenkov light for calorimetric applications also raised a great deal of interest at the workshop.

In summary, the intense scientific sessions and the numerous talks and contributions at RICH2007 resulted in a picture of great vitality. This was clear from the inspiring introductory talk by Blair Ratcliff of SLAC and in the summary of highlights by Silvia Dalla Torre of Trieste. The participants also benefited from the workshop's location in the centre of Trieste, directly on a pier, and a social programme that included a visit to the Roman ruins of Aquileia's river harbour and basilica, a walk through the huge Karst cave Grotta Gigante and a choir recital in Trieste's cathedral. RICH practitioners already look forward to the next meeting, where appealing host sites have been proposed, such as Marseille and KEK.

● RICH2007 was sponsored by several Italian and other European institutions and private companies. These included INFN, Hadron Physics I3, CERN, the University of Trieste, the Consorzio per la Fisica and Sincrotrone Trieste. For more information, see <http://rich2007.ts.infn.it/sponsors.php>.

### Further reading

Slides of all of the talks and posters can be downloaded from <http://rich2007.ts.infn.it/>. The proceedings of the workshop will be published by Elsevier in the journal *Nuclear Instruments and Methods in Physics Research A*.

### Résumé

*L'atelier de Trieste expose un RICH éventail*

*Les compteurs RICH (Ring Imaging Cherenkov – Tcherenkov à focalisation annulaire) sont uniques pour identifier les particules chargées en mesurant leur vitesse. Bien établis en physique des hautes énergies et en astrophysique des particules, ils s'utilisent de plus en plus dans le cadre des expériences haute résolution et haute précision, et les nouveaux détecteurs se font de plus en plus exigeants. Le 6<sup>e</sup> atelier international sur les compteurs RICH, qui s'est tenu à Trieste du 15 au 20 octobre 2007, a présenté toutes leurs applications, réunissant des experts du monde entier pour analyser l'état de l'art et les perspectives du domaine.*

**Silvia Dalla Torre**, INFN–Trieste.

# RECRUITMENT

For advertising enquiries, contact *CERN Courier* recruitment/classified, IOP Publishing, Dirac House, Temple Back, Bristol BS1 6BE, UK.  
Tel +44 (0)117 930 1027 Fax +44 (0)117 930 1178 E-mail [sales@cerncourier.com](mailto:sales@cerncourier.com)  
Please contact us for information about rates, colour options, publication dates and deadlines.

## Foundation for Fundamental Research on Matter

*The Foundation for Fundamental Research on Matter (FOM) promotes, co-ordinates and finances fundamental and applied physics research of international standard/calibre in The Netherlands. It is an autonomous foundation responsible to the physics division of the national research council NWO. FOM employs about 1000 people, primarily scientists (including PhD students) and technicians, who work at FOM research institutes and research groups at universities. FOM is chiefly financed by the NWO (Netherlands Organisation for Scientific Research) Governing Board and NWO Physics and can be considered as the Physics Division of NWO. In addition to the government funds of NWO, FOM acquires financial means from the European Union and through collaboration with the industry and universities. For additional information see <http://www.fom.nl>*



Nikhef is the national institute for subatomic physics in the Netherlands with ca. 250 employees of which about 120 physicists. It is a collaboration between four universities and the funding agency FOM. The institute co-ordinates and supports major activities in experimental subatomic physics in the Netherlands such as the preparation of experiments at the Large Hadron Collider at CERN, notably ATLAS, LHCb and ALICE. The Nikhef scientific programme also includes several astroparticle physics projects, in particular through participation in the ANTARES neutrino telescope, the AUGER cosmic-ray observatory and the VIRGO gravitational-wave interferometer.

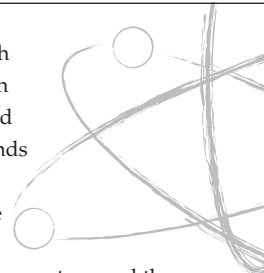

The Nikhef detector R&D group is active in the development of state-of-the-art detector technologies for accelerator-based particle physics and astroparticle physics experiments as well as for detector R&D collaborations like Medipix and RD51 at CERN. Collaborations with industrial partners are actively pursued.

Nikhef has two staff positions for a

## physicist with a focus on advanced detector technologies

### Requirements

The applicant has a PhD in particle physics or engineering and experience with development of advanced detector - and associated electronics technology. Applicants are expected to avail of good communication skills and are able to work in an (international) team of physicists and engineers. They are also expected to develop new initiatives and to take a leading role in the development of modern particle physics detectors. Experience with multi-disciplinary and industrial partners is an advantage.

### Information

Further information can be obtained from the leader of the detector R&D group, dr. J.J.M. Timmermans (phone +31 20 5925112 or by email [jan.timmermans@nikhef.nl](mailto:jan.timmermans@nikhef.nl)) or from the chairman of the selection committee,

prof. dr. M.H.M. Merk (phone +31 20 5925107 or by email [marcel.merk@nikhef.nl](mailto:marcel.merk@nikhef.nl)).

Job interviews are foreseen in the period May 26th, 2008 until June 13th, 2008.

### Applications

Candidates are invited to send their application, including curriculum vitae, list of publications as well as three letters of reference before May 15th, 2008 to Nikhef, att. Mr. T. van Egdom, P.O. Box 41882, NL-1009 DB Amsterdam, or by email [teus.van.egdom@nikhef.nl](mailto:teus.van.egdom@nikhef.nl). Please quote vacancy number: PZ-080215.

All qualified individuals are encouraged to apply.



**cerncourier.com**

**IOP Publishing**



KIT – The cooperation of Forschungszentrum Karlsruhe GmbH and Universität Karlsruhe (TH)

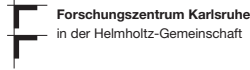

The Universität Karlsruhe (TH) and the Forschungszentrum Karlsruhe are combining their activities in the Karlsruhe Institute of Technology (KIT). Forschungszentrum Karlsruhe is one of the largest science and engineering research institutions in Europe and member of the Helmholtz Association of National Research Centres, that follows long-term research aims of state and society in scientific autonomy.

The KIT announces an opening for the joint position of

**Full Professor (W3)  
for High Power Microwave Techniques  
at the Universität Karlsruhe (TH)**

and

**Head of the Institute  
for Pulsed Power and Microwave Technology (IHM)  
at the Forschungszentrum Karlsruhe.**

The Institute for Pulsed Power and Microwave Technology (IHM) is one of the world wide leading institutions for the development of high power gyrotrons especially for plasma heating in fusion reactors. Research activities include the development of oversized wave guides, quasi-optical transmission lines and microwave measurement techniques.

We are seeking a candidate with a record of outstanding scientific achievements and an international reputation. A well-founded background and an innovative approach in at least one of the above given research areas are required. Additional experiences in the pulsed power technology and in the development of microwave resonators and applicators for material processing are welcome. Beside a strong scientific profile the candidate should also be experienced in personnel management of large teams.

It is expected that the candidate strengthens and expands the cooperation inside KIT as well as in the European and world wide research network in the area of heating and diagnostics of fusion plasmas.

Teaching duties would cover subjects in the field of high power microwaves with their large variety of applications as well as microwave measurement techniques and microwave circuit design. Additionally, participation in the new KIT study courses in the area of energy research is expected.

Candidates must have a proven record of research and teaching as documented by a habilitation or equivalent qualifications acquired in non-university employment.

Applications of qualified women are strongly encouraged, as we wish to increase the proportion of female scientists on the management level.

Handicapped applicants having the same qualification will be given preference.

Applications with the customary documents (curriculum vitae, certificates, list of publications, including selected reprints, as well as documentation of previous research and teaching activities) shall be addressed to

**Dean of the Department of  
Electrical Engineering and Information Technology**

**Universität Karlsruhe (TH), Kaiserstr. 12, 76131 Karlsruhe, Germany**

and in parallel to

**Prof. Dr. Reinhard Maschuw, Member of the Executive Board  
Forschungszentrum Karlsruhe, P.O. box 3640, 76021 Karlsruhe, Germany**

by **April 30, 2008.**

In addition, please submit your application in electronic form  
(e-mail: [dekanat@etit.uni-karlsruhe.de](mailto:dekanat@etit.uni-karlsruhe.de) and  
[reinhard.maschuw@vorstand.fzk.de](mailto:reinhard.maschuw@vorstand.fzk.de)).

[www.kit.edu](http://www.kit.edu) [www.uni-karlsruhe.de](http://www.uni-karlsruhe.de) [www.fzk.de](http://www.fzk.de) [www.fzk.de/ihm](http://www.fzk.de/ihm)

PAUL SCHERRER INSTITUT

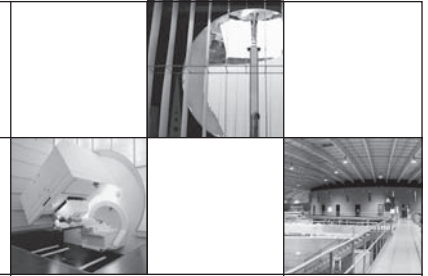

The Paul Scherrer Institut is a centre for multi-disciplinary research and one of the world's leading user laboratories. With its 1300 employees it belongs, as an autonomous institution, to the Swiss ETH domain and concentrates its activities on solid-state research and material sciences, elementary particle and astrophysics, energy and environmental research as well as on biology and medicine.

For the new project of a X-ray Free Electron Laser at PSI (PSI-XFEL) we are looking for a

# Project Leader

## Your tasks

Based on the success of the realization and operation of the Swiss Light Source (SLS), funding has recently been approved for the construction of the first stage (250 MeV injector) of an X-FEL at PSI. In a second stage, a request will be submitted to build a full X-FEL facility, which will further foster the excellence in photon science and complement the muon and neutron sources at PSI.

The PSI-XFEL with its fully coherent, short pulse (femtoseconds) radiation with orders of magnitude higher power and brightness than those currently achievable at synchrotrons will make this facility an extremely valuable light source for scientific research. It is based on novel concepts for electron emission, high gradient acceleration and effective bunch compression.

The Project Leader will be responsible for the scientific-technical and managerial leadership of the project relying on a highly experienced accelerator physics staff and strong infrastructure support. He/she will maintain and develop a strong collaboration with other FEL-institutes, as well as with the team in charge of preparing the PSI-XFEL scientific case for the second stage. He/she will report directly to the PSI-Director.

## Your profile

The successful candidate is expected to have an international recognized expertise in the field of accelerator physics and experience with free electron lasers. He/she should have demonstrated success in leading and managing large accelerator projects.

## We are looking forward to your application.

For further information contact Prof. J. Mesot, Tel. +41 (0)56 310 4029, E-mail: [joel.mesot@psi.ch](mailto:joel.mesot@psi.ch), or Prof. L. Rivkin, Tel. +41 (0)56 310 3214, E-mail: [leonid.rivkin@psi.ch](mailto:leonid.rivkin@psi.ch).

Please submit your application to:  
Paul Scherrer Institut, Human Resources, Mr. Thomas Erb,  
ref. code 0600, 5232 Villigen PSI, Switzerland, or [thomas.erb@psi.ch](mailto:thomas.erb@psi.ch).

Further job opportunities: [www.psi.ch](http://www.psi.ch)



The Abdus Salam  
International Centre for Theoretical Physics



The Abdus Salam International Centre for Theoretical Physics (ICTP), is a world-class institution, operating under the aegis of UNESCO and IAEA focused on research in basic sciences with responsibility for the promotion, dissemination and support of science, especially in developing countries. The Public Information Office is to be rebuilt and for this we are seeking a:

#### PUBLIC INFORMATION OFFICER

The successful candidate will be responsible for the information, statistics and documents on ICTP aimed at giving visibility to the organization's mandate and activities. The incumbent will be also expected to identify public information needs and opportunities within ICTP, develop communication strategies, prepare and disseminate press releases and to be the contact person for national and international media.

All candidates must possess:

- Advanced university degree or PhD in physics or mathematics, chemistry, biology, science journalism, communication or public relations
- At least four (4) years of experience in public information or communications or scientific dissemination of which preferably 2 acquired at the international level
- Good knowledge of Microsoft Office and publishing software
- Excellent knowledge of written and spoken English. Knowledge of Italian would be an asset
- A positive attitude towards the international and multicultural characteristics of the assignment

Please find further information about ICTP, the vacancy and the on-line application form at <http://portal.ictp.it/vacancy>.

Deadline for receipt of applications: 18 April 2008."



National Taiwan University  
High Energy Physics Group

### Postdoctoral Positions in Experimental Particle Physics

The High Energy Physics Group at NTU has made outstanding performance in Belle physics analysis, and now has several postdoc positions available in

- a) CMS analysis and Grid (with possibility of stationing at CERN),
- b) Super Belle upgrade, c) Daya Bay neutrino experiment, and d) a novel 100 PeV neutrino telescope prototype involving 1000 PMT channels.

The positions can start any time in 2008.

Contacts: Prof. George W.S. Hou (+886-2-33665096,  
[wshou@phys.ntu.edu.tw](mailto:wshou@phys.ntu.edu.tw))

or Prof. Y. Bob Hsiung (+886-2-33665135,  
[yhsiung@phys.ntu.edu.tw](mailto:yhsiung@phys.ntu.edu.tw)).



## Forschungszentrum Karlsruhe in der Helmholtz-Gemeinschaft

The Forschungszentrum Karlsruhe GmbH, member of the Helmholtz Society, is one of the leading research centres of Europe. Its synchrotron light source ANKA will be built up to a national and European user facility on specific science areas. Its 2.5 GeV storage ring provides light from hard X-rays to the far-infrared for spectroscopy, scattering, imaging and lithography. ANKA focuses on the use of synchrotron radiation for micro- and nanotechnologies, condensed matter research, actinide and environmental research and on the development of synchrotron technology.

For the current expansion of ANKA we are looking for the following staff:

#### Scientists/Senior Scientist for

- spectroscopy methods (530/2007)
- coherent X-ray micro imaging methods and instrumentation (195/2007)
- development of modern synchrotron X-ray diffraction techniques (225/2007)
- undulators development (469/2007)

Detailed information about these vacancies can be found at <http://jobs.fzk.de>.

For more information please contact Prof. Dr. Baumbach, Tel. +49 (0)7247 82-6820 or Mrs Mäurer +49 (0)7247 82-5006.

Kindly send your application until 6th of April 2008 to Mrs Mäurer, HPS, making explicit reference to the vacancies or apply online <http://jobs.fzk.de>.

Forschungszentrum Karlsruhe GmbH  
in der Helmholtz-Gemeinschaft  
Hauptabteilung Personal und Soziales  
Postfach 36 40, 76021 Karlsruhe, Germany

Internet: [www.fzk.de](http://www.fzk.de)

### cerncourier.com

For information and consultative advice on classified advertising in CERN Courier and the Web options that we offer, please contact Moo Ali  
Tel +44 (0)117 930 1264 E-mail [moo.ali@iop.org](mailto:moo.ali@iop.org)

IOP Publishing

# MAY ISSUE

**Booking Deadline: Friday 4 April**

**Copy Deadline: Monday 7 April**

**Distribution: Wednesday 16 April**

**Call Moo Ali on +44 (0)117 930 1264 for more details**

IOP Publishing

# FACES AND PLACES

## AWARDS

# EPS announces 2008 Accelerator Prizes



Alex Chao. (Courtesy Diana Rogers/SLAC.)



Norbert Holtkamp. (Courtesy ITER.)



Viatcheslav Danilov. (Courtesy VV Danilov.)

The European Physical Society (EPS) has announced the names of the recipients of the 2008 prizes for work in the field of particle accelerators. The prizes are awarded by the Accelerator Group of the EPS, on the recommendation of a committee chaired this year by Leonid Rivkin of PSI and the Ecole Polytechnique Fédérale de Lausanne.

Alex Chao of SLAC receives the 2008 achievement prize for outstanding work in the accelerator field, with no age limit, “for many ground-breaking and fundamental contributions to accelerator physics, and

for the direct or indirect contribution to the design and performance of almost every major accelerator project, built or not built, over the past 30 years”.

A second achievement prize for a recent, significant contribution to the accelerator field, with no age limit, goes to Norbert Holtkamp of ITER. Previously at Oak Ridge National Laboratory (ORNL), he receives the award “for his role in the construction and successful commissioning of the Spallation Neutron Source (SNS) on time and to budget, within the constraints of a

multilaboratory collaboration”.

A prize for an individual in the early part of his or her career, who has made a recent, significant and original contribution to the accelerator field, goes to Viatcheslav Danilov, also of ORNL/SNS, “for numerous contributions to accelerator physics, in particular for the proposal, calculation, design, construction and demonstration of efficient laser H<sup>-</sup> stripping”. The three prizewinners will receive their awards at the 2008 European Particle Accelerator Conference in Genoa on 23–27 June.

## APPOINTMENTS

# ALICE physicist will head the Mexican Academy of Sciences

Arturo Menchaca-Rocha has been elected to be vice-president of the Mexican Academy of Sciences (AMC).

The academy, which represents Mexican science internationally, gathers the most distinguished Aztec researchers and constitutes an important forum to guide the Mexican government on scientific policies.

Among other activities, the AMC also runs a popular outreach programme, where members give talks to the general public on

Sundays in many cities throughout Mexico.

Menchaca-Rocha, who until last year directed the Institute of Physics at the National Autonomous University of Mexico, is also a member of the collaboration building the ALICE experiment for the LHC. He is leader of the group that designed, built and operates a key part of the triggering system for ALICE, called the VOA. Vice-presidency of the AMC is a two-year post that automatically leads to the presidency for two more years.



Arturo Menchaca-Rocha. (Courtesy C Pardo.)



## CELEBRATION

# Superheavy element pioneer reaches 75

Yuri Oganessian celebrates his 75th birthday on 14 April. He is well known for his work on the physics of the atomic nucleus and nuclear reactions, and experiments on the synthesis of new elements in the periodic table.

His scientific career has been closely tied to the JINR in Dubna, where he was assigned after graduating from the Moscow Engineering Physics Institute in 1956. At JINR he rose to become director and scientific leader of the Flerov Laboratory of Nuclear Reactions, and he gained the status of professor and full member of the Russian Academy of Sciences.

In the early 1970s Oganessian formulated the basic principles of synthesizing



Yurio Oganessian. (Courtesy JINR.)

transferrmium elements in reactions of “cold fusion” and conducted fundamental experiments on synthesizing elements

from 100 to 108. Element 105 was named “dubnium” in honour of this work. In the 1990s he launched the programme to synthesize the heaviest isotopes in reactions of calcium-48 with actinide targets. These reactions yielded new elements – 113 to 116 and 118 – the decay properties of which provided direct proof of the existence of the “island of stability” of superheavy elements.

For his achievements, Oganessian has been awarded the USSR State Prize, the Kurchatov Prize, the Flerov Prize, the Humboldt Prize and the Lise Meitner Prize. He is also an honorary doctor of several universities.

## OUTREACH

## LHC is in reach of young people

Detectives, giants and YouTube have all come together in a recent UK initiative to spread the word about the LHC to a wider audience. They all figure in a €1 m programme that the Science and Technology Facilities Council is supporting, in partnership with the particle-physics community, to encourage public engagement with the LHC project.

The exciting new resources include the Particle Detectives, which contains downloadable presentations on the LHC, video clips of students asking and scientists answering questions about the LHC, and an interactive LHC simulator. In Search of



Check out the website for the Particle Detectives.

Giants is a collection of three 15 minute films on particle physics and the LHC that are broadcast to schools. They have also been edited into 15 short clips and uploaded to YouTube. Labreporter is another collection of

video clips about the big questions that the LHC is exploring, which is available on the web and will be broadcast by the BBC on big screens in city centres across the UK around the time of the LHC start-up.

These resources are part of a broad strategy that embraces media work; producing animations; educational resources and a touring exhibition on the LHC; parliamentary liaison, and teacher and VIP visits to CERN.

● For more on the Particle Detectives, see [www.particledetectives.net/html/main.html](http://www.particledetectives.net/html/main.html); In Search of Giants can be downloaded from [www.teachers.tv](http://www.teachers.tv) with the clips available at [www.youtube.com/user/SciTechUK](http://www.youtube.com/user/SciTechUK); [www.lhc.ac.uk](http://www.lhc.ac.uk) is a site for the public and UK schools, which includes an area for physicists to share resources and ideas for public outreach activities.

## LETTER

### The (non)science of the multiverse

The article “Physics in the multiverse” (p13) in the December issue of *CERN Courier* annoyed me. In my opinion the multiverse(s) of the type that Aurelian Barrau describes are not science.

Science owes its success in, and acceptance by, society to a delicate balance between theory and experiment, namely to the ability of scientists to make clear honestly on which experimental facts their claims of explaining natural phenomena are based. Beautiful mathematical structures are science in their

own right, but declaring them physical reality just because of their beauty is unscientific, especially if the main motivation is the inability to make verifiable (or falsifiable) predictions.

The author lists the criteria that are generally accepted for some statements to be called scientific. Yet his post-modernist claim that these criteria can and should be adapted to the flights of fancy of theoreticians is wrong. The dangers of such an attitude must not be underestimated. What has recently come down to the public as books and

articles about multiverses looks to me like an ideological brainwash and a sales campaign. Everyone is free to believe what they like but we must not allow this to be called science. Too often in the past, private world views based on fanciful extrapolations of scientific facts turned out wrong. This is not just bad for those who held these views: the damage done to the credibility of the scientific community at large may well exceed what these fellows can take responsibility for.

*Peter Schmid, Salzburg.*

## CENTENARY

# Scientists hold a symposium for Mięśowicz

On 23 November 2007 some 200 members of the Polish scientific community attended a symposium in Kraków to celebrate the 100th anniversary of the birth of Marian Mięśowicz, one of the greatest Polish physicists.

Mięśowicz was a founder of particle physics in Kraków, where he was professor of physics at the University of Science and Technology (AGH) and at the Institute of Nuclear Physics of the Polish Academy of Science (IFJ PAN).

He studied physics and received his PhD at the Jagiellonian University in 1932. Two years later, as an assistant professor in the Physics Department at the Kraków University of Mining (now the AGH), he began his pioneering research on the hydrodynamics of liquid crystals that resulted in the discovery of anisotropy in their viscosity. He defined and measured the viscosity coefficients for liquid crystals, now known as “Mięśowicz’s coefficients”, a term introduced by Pierre-Gilles de Gennes.

His results, published in *Nature* in 1935 and 1946 (the second publication delayed by the outbreak of the Second World War), had a strong impact on the development of a dynamical theory of nematic liquid crystals and are still frequently cited. In the mid-1930s Mięśowicz became interested in nuclear and cosmic-ray physics, and, after a few years’ break caused by the war, he continued his studies of the penetrating component of cosmic rays in the Wieliczka salt-mine near Kraków. Using experimental equipment that they built themselves, Mięśowicz and a small group of collaborators confirmed the existence of a penetrating component in cosmic rays and the presence of a weakly ionizing isotropic component, which was strongly absorbed by lead.

Mięśowicz correctly attributed this latter component to the natural radioactivity of the surrounding medium, contrary to earlier interpretations. The result was the first research paper based entirely on Polish-made detectors, which was published in *Physical Review* in 1950, after the war. This publication, cited many times, was a cornerstone of the wide international collaboration that the Kraków high-energy physics community established, and which



Marian Mięśowicz. (Courtesy family archives.)

still continues. The measurements in Wieliczka also initiated collaboration with geologists and the development of Polish nuclear geophysics.

In the 1950s Mięśowicz went on to initiate studies of cosmic-ray interactions in Kraków using nuclear emulsions. Important results from the Kraków emulsion group included studies of electromagnetic cascades, which provided the first observation of the Chudakov effect (the screening of electrical charges) and confirmed coherence effects in the radiation of photons by high-energy electrons, as predicted by the Landau–Feinberg–Migdal–Pomeranchuk theory. The studies of hadronic showers (jets) produced in interactions of high-energy cosmic rays with the emulsion nuclei led to the postulation of the “fireball model”, so called by Giuseppe Cocconi. This was the first attempt to understand the process of multiple particle production in terms of the interparticle correlations, and it later became a standard tool of analysis. Mięśowicz understood that collisions with nuclear targets in emulsion could provide information that was unobtainable from hadron–hadron collisions. The concept of the formation zone,

which fascinated many experimentalists and theoreticians, was an important consequence of this approach.

Mięśowicz strongly influenced the development of contemporary physics in Poland. He led the involvement of particle physicists from Kraków in experiments on accelerators, starting from emulsions, then moving to bubble chambers and finally electronic experiments. High-energy experimental groups, totalling about 100 physicists, engineers and technicians, were established under him at both the IFJ PAN and the AGH. These groups have participated in, and continue to contribute to, dozens of experiments at CERN, DESY, Fermilab, Brookhaven National Laboratory, KEK and the Pierre Auger Observatory. Mięśowicz also stimulated theoretical studies of elementary particle physics in Kraków, and the theory group became internationally recognized in the field.

Mięśowicz was a member and a vice-president of the Polish Academy of Sciences, a member of the Polish Academy of Arts and Sciences and a Polish MP. Despite his numerous duties, he never gave up physics. While leaving much freedom to his collaborators, he remained keenly interested in their results and achievements, encouraging them to undertake difficult tasks, and was he always ready to help. He was also a dedicated teacher, proud that he never missed giving his lectures unless seriously ill.

To commemorate the centennial of Mięśowicz’s birth, physicists at Kraków, former students and friends organized a one-day scientific symposium on 23 November, which reviewed the physics disciplines that had interested him and, in particular, his contributions. There were excellent review talks and memorial speeches by several outstanding physicists, including Nobel laureates Martin Veltman and Frank Wilczek. The organizers hope that Mięśowicz achievements, and in particular his passion for physics, will continue to inspire future generations of physicists.

● For presentations at the symposium see [http://miesowicz.ifj.edu.pl/index\\_eng.php](http://miesowicz.ifj.edu.pl/index_eng.php).

## VISITS



**Slobodan Backović** (right), Montenegro Minister of Education and Science, visited CERN on 7 December 2007 to sign a co-operation agreement. During the visit, he toured the ALICE experiment. Here he admires one of the crystals for the photon spectrometer, together with **Sanja Damjanović**, a CERN fellow and a member of the ALICE collaboration.



Deputy Prime Minister and Minister for Science and Education for the Republic of Bulgaria, **Daniel Valtchev** (right), visited CERN on 18 December 2007, when he toured the CMS experimental cavern together with CMS spokesperson, **Tejinder Virdee**. During the visit, **Valtchev** also toured the LHC computing centre and the LHC superconducting magnet test hall, and he met with Bulgarian staff members contributing to CERN projects.

## NEW PRODUCTS

**Aitech Defense Systems Inc** has announced the 3U CompactPCI S950, a high-performance, single-slot, single-board computer that allows the user to initiate different power-saving options. It uses 13.5 W in full operation, with a core processor speed of 733 MHz. The board incorporates the low-power Power PCTM 750FX Processor with a maximum power dissipation of less than 8 W, and 128 MB of SDRAM. For more information, tel +1 888 248 3248; e-mail sales@rugged.com, or see www.rugged.com.

**Southern Scientific** has unveiled the Inspector EXP+, a low-cost, hand-held radiation detector with an external probe, LCD digital readout and audible indication of each count detected. The Inspector EXP+ is part of the Radiation Alert range from SE International and offers sensitivity to low levels of alpha, beta, gamma and X-rays. The detector provides an accuracy of  $\pm 10\%$  in the 1–1000  $\mu\text{Sv/hr}$  range with reference to 137 Cs. For further details, tel +44 1903 604 000; fax +44 1903 604 026 or see www.ssl.gb.com.

**HiTek Power** has announced the XR1000 and XR2000 series of X-ray generator power supplies – 1 kW and 2 kW rack-mounted units that

produce the tightly controlled power needed to drive and control X-ray tubes. They offer output voltages of up to 60 or 90 kV with a closed-loop beam current control system coupled with high stability and low ripple. Filament current and voltage are sensed at the output terminals of the high-voltage connector. For further details, contact Michelle Quiggan tel +44 190 371 2400; e-mail mquiggan@hitekpower.com; or see www.hitekpower.com.

**Spellman High Voltage Electronics Corporation** has introduced the ML430, a compact, surface-mount module featuring bipolar outputs of +430 Vdc at 12 mA and – 430 Vdc at 25 mA. Air insulated, it is small enough to fit into most space-restricted applications. The ML1350, also recently announced, provides a printed circuit-board mountable, high-voltage power supply, specifically configured to drive the quadrupoles used in mass spectrometers and electrostatic lens applications. Input voltage is specified at +24 Vdc,  $\pm 1.2$  Vdc at 3 A, and two sets of bipolar outputs are provided, including  $\pm 1350$  Vdc and  $\pm 245$  Vdc. For more information, tel +1 631 630 3000 or see www.spellmanhv.com.

## MEETINGS

The **20th Rencontres de Blois** will be held in Blois, Loire Valley, on 18–23 May. The conference, which will focus on Challenges in Particle Astrophysics, will consist mainly of plenary sessions, but half a day will be devoted to parallel sessions on ultra-high-energy cosmic rays, gamma-ray astronomy, dark matter and cosmology, and neutrinos. For more detailed information, see <http://blois.in2p3.fr/2008/>.

The **Third International Accelerator School for Linear Colliders** will be held on 19–29 October at Oak Brook Hills Marriott Hotel near Chicago. The programme includes eight days of lectures on accelerators and a one-day site visit to Fermilab, where hands-on training in a control room will be given. The school encourages young physicists to apply and welcomes in particular those physicists who are considering changing to a career in accelerator physics. Students will receive financial aid covering their expenses,

including travel (full or partial). Each applicant should complete the online registration form and submit a curriculum vitae as well as a recommendation letter from his or her supervisor (in electronic form: either PDF or Microsoft Word). The deadline for application is 1 May 2008. For further information, see [www.linearcollider.org/school/2008/](http://www.linearcollider.org/school/2008/).

The **2008 Hadron Collider Physics Symposium (HCP2008)** will take place in Galena, Illinois, on 27–31 May. Sponsored by Fermilab, Fermi Research Alliance, LLC and the US Department of Energy, this symposium has been a major forum for the presentation of Tevatron measurements over the past two decades. The programme for 2008 will include sessions on top physics, the Standard Model, QCD, B physics, new phenomena, electroweak symmetry breaking, and the LHC machine and experiment status. The registration deadline is 16 May. For further information, see <http://conferences.fnal.gov/hcp/>.

OBITUARY

# Iuliu Stumer 1942–2008

It is with deep sorrow that we heard of the passing of Iuliu Stumer, a longstanding member of the Physics Department at Brookhaven National Laboratory, on 3 February in Tel Aviv.

Iuliu contracted polio at a young age in Romania but did not let this disability slow him down. He moved to Israel in 1960, where he undertook undergraduate studies at the Technion and continued at Tel Aviv University for his MSc and PhD. He already displayed great talents as a student. For his PhD experiment he collaborated with the Heidelberg bubble chamber group and in the summers drove from Tel Aviv to Heidelberg, using ferries between Haifa and Italy.

On graduation Iuliu joined Brookhaven National Laboratory, where he stayed until his retirement in 2007. He excelled there and was called on to contribute to various basic research projects. His first major experiment as part of the Brookhaven group took him to Fermilab, where the collaboration made measurements of neutral particles, such as  $\pi^0$  and  $\eta$ , with high transverse momentum, reflecting the differing parton distributions of the various beam particles.

Following this work, Iuliu moved to CERN where he was involved in experiments at the ISR: first R806 and later R807. He loved working in CERN's exciting environment and really came into his own at the ISR. With R806 he was in charge of developing the software for reconstruction and for data analysis. The amount of data was large (for those days) and the 1500 tapes that were to be analysed were shipped to Brookhaven. To encourage the operator at the computer centre to give priority to this tape handling, Iuliu installed a few well placed bottles of wine between the tapes. This did the trick and the experiment took priority. This was Iuliu at his best – getting the physics done and motivating people to do the job. The experiment was a



*Iuliu Stumer. (Courtesy Howard Gordon.)*

great success with the discovery of single photon production and many other interesting phenomena. It was also the first large-scale application of the liquid-argon calorimeter technique, and Iuliu became one of the world experts in the analysis of liquid argon data and understanding the subtle behaviour of these calorimeters.

During that time, Brookhaven had trouble with the magnet design for the proposed collider, ISABELLE, so Iuliu was drafted in to work on the design of several new magnet

concepts. He made critical calculations for many of these, one of which – the two-in-one dipole – is now implemented in the LHC machine at CERN. After the cancellation of ISABELLE, Iuliu worked for a few years on novel acceleration techniques.

Following this, he returned to CERN to work on the NA34/HELIOS experiment where again he was involved in liquid-argon calorimetry and the development of conceptual designs for experiments at large hadron colliders. He became involved in the GEM experiment for the Superconducting Supercollider (SSC) project in the US, working mainly on the liquid-argon calorimeter and developing a novel design for the electrodes to optimize photon identification. Since 1993, and with the cancellation of the SSC, he was involved in the ATLAS experiment for the LHC, where he worked first on the liquid argon calorimeter and then on the muon system.

Iuliu's experience and expertise was appreciated by many, and his door was always open to people who came to consult him on their latest analysis problem. He was always ready with advice and guidance. He was also a true friend, ready to help others while refusing to get help for himself. He was the loving "uncle" to many of his younger colleagues, who became his friends as they grew older. He loved travelling, and when at CERN he would take off for a "short" drive from Geneva to the far corners of Europe, always coming back full of stories and enthusiasm.

In 1998 Iuliu married Odette Benary, a friend and colleague from Tel Aviv. They lived in New York and Tel Aviv, until his retirement from Brookhaven, when they decided to return to Israel to be close to Odette's children and grandchildren.

Iuliu will be sorely missed by all of those who were fortunate to have known him. *His family, friends and colleagues from all over the world.*

CORRECTIONS

- The article "From BCS to LHC" in the January/February issue unfortunately gave the wrong first name for Abdus Salam's collaborator on symmetry groups in weak

interactions (p21). This should, of course, have been John Ward.

- The obituary of Engin Arik on p36 of the

March issue mistakenly referred to Turkey as an associate member of CERN. There are no associate members of CERN. Turkey has had observer status since 1986.

# BOOKSHELF

## Books received

**Laser Control of Atoms and Molecules** by Vladilen S Letokhov, Oxford University Press. Hardback ISBN 9780198528166 £55 (\$110).

The general term “laser control of atoms and molecules” covers a variety of problems, including the laser selection of atomic and molecular velocities for the purpose of Doppler-free spectroscopy; laser trapping and cooling of atoms; and laser control of atomic and molecular processes (ionization, dissociation) with a view to detecting single atoms and molecules and, in particular, separating isotopes and nuclear isomers. During the past decade, the principal problems have been successfully solved, many evolving in subsequent research worldwide. The aim of this book by one of the acknowledged experts in the field is to review these topics from a unified point of view, providing a resource for researchers in the various different fields.

**Optical Trapping and Manipulation of Neutral Particles Using Lasers: a Reprint Volume with Commentaries** by Arthur Ashkin, World Scientific. Hardback ISBN 9789810240578 £102 (\$187). Paperback ISBN 9789810240585 £58 (\$106).

This volume by the pioneer of optical trapping and “optical tweezers” contains selected papers and extensive commentaries on laser trapping and the manipulation of neutral particles using radiation pressure forces. These optical methods have had a revolutionary impact on the fields of atomic and molecular physics, biophysics and many aspects of nanotechnology. With his colleagues, Ashkin first demonstrated optical levitation, the trapping of atoms, and “tweezer” trapping and manipulation of living cells and biological particles. This extensive review should be of interest to researchers and students in atomic physics, molecular physics, biophysics and nanotechnology.

**Classical Charged Particles** (third edition) by Fritz Rohrlich, World Scientific. Hardback ISBN 9789812700049 £33 (\$58).

Originally written in 1964, this text is a study of the classical theory of charged particles. Many applications treat electrons as point particles, but there is nevertheless a widespread belief that the theory is beset with various difficulties, such as an infinite

electrostatic self-energy and an equation of motion that allows physically meaningless solutions. The classical theory of charged particles has meanwhile been largely ignored and left incomplete. Despite the efforts of great physicists such as Lorentz, Poincaré and Dirac, it is usually regarded as a “lost cause”. Thanks to more recent progress, however, the author has been able to resolve the various problems and to complete this unfinished theory successfully.

**Principles of Phase Structures in Particle Physics** by Hilegard Meyer-Ortmanns and Thomas Reisz, World Scientific. Hardback ISBN 9789810234416 £71 (\$131).

The phase structure of particle physics shows up in matter at extremely high densities and/or temperatures as reached in the early universe or in heavy-ion collisions in modern laboratory experiments. This book cover the various analytical and numerical tools needed to study this phase structure. These include convergent and asymptotic expansions in strong and weak couplings, dimensional reduction, renormalization group studies, gap equations, Monte Carlo simulations with and without fermions, finite-size and finite-mass scaling analyses, and the approach of effective actions as a supplement to first-principle calculations.

**Relaxation Processes in Micromagnetics** by Harry Suhl, Oxford University Press. Hardback ISBN 9780198528029 £49.95 (\$150).

Electrons in solids behave like microscopic bar magnets, and in certain solids these align to produce macroscopic magnetizations. This book deals with the dynamics of this magnetization field, which is intrinsically nonlinear. This is important in applications, particularly magnetic recording, which involves very large motion of the magnetization, well beyond the validity of linearized (small motion) approximations or their limited extensions. The author therefore emphasizes nonlinear solution methods but with only minimal use of numerical simulation. The book should be useful to physicists studying magnetic phenomena.

**Mesoscopic Physics of Electrons and Photons** by Eric Akkermans and Gilles Montambaux, Cambridge University Press. Hardback ISBN 9780521855129 £55 (\$99).

Quantum mesoscopic physics covers a

whole class of interference effects related to the propagation of waves in complex and random media, ranging from the behaviour of electrons in metals and semiconductors to the propagation of electromagnetic waves in suspensions such as colloids, and quantum systems like cold atomic gases. A solid introduction to the field, this book addresses the problem of coherent wave propagation in random media. With more than 200 figures, and exercises throughout, it will be useful for graduate students in physics, applied physics, acoustics and astrophysics.

**The Power of  $\alpha$ : Electron Elementary Particle Generation with  $\alpha$ -Quantized Lifetimes and Masses** by Malcolm H MacGregor, World Scientific. Hardback ISBN 9789812569615 £50 (\$93).

This book focuses on the most pressing unsolved problem in elementary particle physics – the mass generation of particles. It contains physics that is not included in the Standard Model as it is now formulated but at the same time is in conformity with its major results (i.e. isotopic spins and interactions). It differs from the Standard Model in the treatment of masses and pseudoscalar mesons, and in the role assigned to the coupling constant,  $\alpha$ . Presented in a careful and phenomenological way, the material can easily be followed by all physicists, both experimental and theoretical, and also by interested workers in other fields.

**Subatomic Physics** (third edition) by Ernest M Henley & Alejandro Garcia, World Scientific. Hardback ISBN 9789812700568 £56 (\$98). Paperback ISBN 9789812700575 £33 (\$58).

This is the third and fully updated edition of a classic textbook, which provides an up-to-date and lucid introduction to both particle and nuclear physics. Topics are introduced with key experiments and their background, encouraging students to think and allow them to do back-of-the-envelope calculations in a diversity of situations. Suitable for experimental and theoretical physics students at the senior undergraduate and beginning graduate levels, the book covers earlier important experiments and concepts as well as topics of current interest, with extensive use of photographs and figures to convey concepts and experimental data.

## An Indian dream come true

India's accelerator pioneers began to build the Calcutta cyclotron in the early 1970s but soon found that the industrial infrastructure was not geared up to provide the necessary level of technology. They had, for instance, difficulty in finding a suitable manufacturer for the essential resonator tank. The Garden Reach Ship Builders said they could build watertight ships but had no experience in making tanks that had to be airtight, maintaining a high vacuum ( $10^{-6}$  torr). But build it they did, and the cyclotron was commissioned in June 1977. It is still working well and has catered for almost two generations of experimental nuclear physicists.

In the early 1980s some of us wanted to build a detector to be used at CERN's SPS to register photons as signals of quark-gluon plasma (QGP), formed in the collision of two nuclei at laboratory energies of typically 200 GeV/nucleon. The protons and neutrons of an atomic nucleus at this energy should "melt" into their fundamental constituents, the quarks and gluons, rather as in the primordial universe a few microseconds after the Big Bang.

The adventure of building a photon multiplicity detector (PMD) was inspiring but not easy. The sheer size and complexity was daunting; the required precision even more so. All of the pundits (i.e. distinguished elderly scientists on funding committees) unanimously declared the project impossible and too ambitious, and generally questioned our credibility. Undaunted, we refused to accept their verdict and against all odds received our initial modest funding.

We did the design in India. The Cyclotron Centre in Calcutta; the Institute of Physics in Bhubaneswar; the universities of Rajasthan and Jammu, and Panjab University joined in. In a short time the group built the PMD, with 55 000 pads, each consisting of a 1–2 cm<sup>2</sup> plastic scintillator. Optical fibres inserted diagonally in each pad picked up the photons – the possible signals of QGP.

The PMD was a great success, unprecedented in modern India, particularly on this scale. It required all kinds of creative innovation, with the best suggestions coming from the youngest members of the team. Almost overnight, India became a key player on

**Bikash Sinha** gives his view of India's emerging role in high-tech experimental particle physics.



*Bikash Sinha. (Courtesy B Sinha, VECC, Kolkata)*

the world stage in this field. This kind of science and the associated precision technology, which had so far remained dormant, began to flourish; there was no looking back.

The PMD later went through a basic design change with the introduction of a "honeycomb" design, and it was shipped across the Atlantic for the STAR experiment at RHIC at the Brookhaven National Laboratory. With a reputation already established at CERN, entry into RHIC posed no problem whatsoever. The PMD has already accumulated a vast quantity of data at RHIC, with good statistics. Complemented by the results from the PHENIX detector, photons look promising as signals of QGP.

Meanwhile, in India we moved from the room-temperature cyclotron to a superconducting cyclotron using niobium-titanium superconducting wire. Hunting for a suitable company to build our cryostat was an adventure. We searched all of India, but drew a blank. Despite our determination we failed to find a suitable company to build the cryostat, and eventually turned to Air Liquide, France, but not without hiccups. We learned how to manage large-scale liquid helium and maintain a steady liquid helium temperature.

Finally, on 11 January 2005, the magnet became superconducting at a temperature of around 4.2 K and maintained the superconducting state for months. It was a fantastic experience. All of January felt

like a carnival. We had made the leap from room-temperature technology to large-scale cryogenic technology.

Meanwhile at CERN, the LHC was looming large on the horizon, with a heavy-ion programme and the ALICE detector. We were thrilled – here was scope for the old workhorse, the PMD, in a more sophisticated guise. Aligarh Muslim University and IIT, Bombay, also joined in our quest. My colleagues at Saha Institute went further, and wanted to participate in the dimuon spectrometer (*CERN Courier* December 2007 p30). Colleagues who had remained dormant or busy with routine jobs, were suddenly inspired. They went on to design the MANAS chip for the muon arm. An Indian company, the Semi Conductor Complex Ltd in Chandigarh, enthusiastically offered to build the hardware. After much debate, the MANAS chip became central to the ALICE muon arm and was accepted worldwide.

Last time at CERN, walking in the shadow of ALICE, marvelling at its size and the immaculate precision with which the work was done, I felt like Alice in Wonderland, with "quarkland" beckoning on the horizon.

In the 1970s, India was still a spectator in the world theatre of high science. Individuals who migrated to other parts of the world sometimes excelled. In India, people were proud of them but remained convinced that such feats could not be accomplished back home. In the 1980s, however, there was a major paradigm shift in our mind set. We began to dream of competing with the world from India.

By the beginning of the 21st century, India was no longer a spectator but a significant player on the world stage. The glamour of individual excellence had been replaced by the wisdom of collective effort. We had turned mature and ambitious. What I have presented is a chronicle of that evolution. I am proud and grateful to be a witness and indeed a participant in this evolving panorama.

The voyage that started almost 30 years ago continues with resolve from LHC to FAIR to an ILC and further, making the impossible possible and turning dreams to reality.

*Bikash Sinha, director, Variable Energy Cyclotron Centre, Kolkata, and director, Saha Institute of Nuclear Physics, Kolkata.*

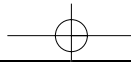

# QUADRUPOLES FOR ADVANCED SCIENCE

## PRECISION GAS ANALYSIS

- Instruments for residual gas analysis (RGA)
- Evolved gas analysis
- TPD/TPR
- Vacuum process monitoring



## UHV SURFACE SCIENCE

- UHV specific pulse counting detector
- Photon and electron stimulated desorption
- Molecular beam studies
- Temperature programmed desorption
- SIMS - high sensitivity surface analysis



## PLASMA CHARACTERISATION

- EQP ion mass and energy analyser
- RF, DC, ECR and pulsed plasma
- Neutrals and neutral radicals
- Time resolved analysis



**HIDEN**  
ANALYTICAL

for further details of Hiden Analytical  
products contact:

[info@hiden.co.uk](mailto:info@hiden.co.uk)

[www.HidenAnalytical.com](http://www.HidenAnalytical.com)

Quadrupoles for advanced science

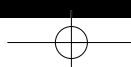

# Introducing the new VME8100 Powered Crates Family

- 19" x 8U (6+2) enclosure
- 21 slot for 6U x 160mm VME modules
- Pluggable Power Supplies and 2U Fan Unit
- CAN bus, Ethernet, USB, RS232 interface
- Automatic Daisy Chain, CBLT compliant

[www.caen.it](http://www.caen.it)

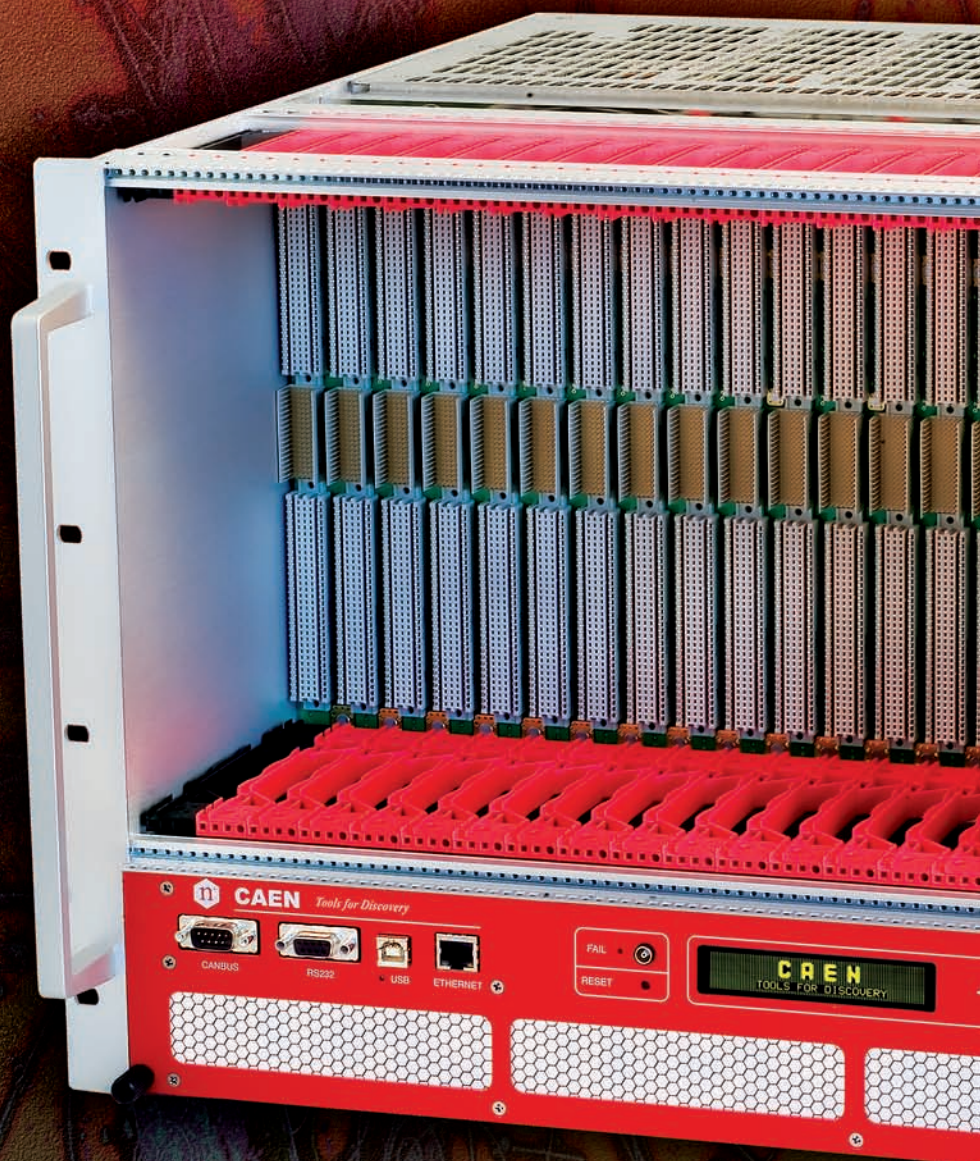

Model - Backplane	+5V	+12V	-12V	+3.3V
VME8100 - VME64	110A / 220A	20A / 40A	20A / 40A	-
VME8100 - VME64x J1/J2	110A / 220A	20A / 40A	20A / 40A	110A / 220A
VME8100 - VME64x J1/J0/J2	110A / 220A	20A / 40A	20A / 40A	110A / 220A

**CAEN: the One-Stop-Shop for the Physics Community**